

CANADIAN MILITARY JOURNAL

Vol. 21, No. 4, Autumn 2021



National
Défence

Défense
nationale

Canada



Cover

“Into Bandit Country” The Boeing CH-47 medium/heavy lift helicopter was a reliable workhorse for Special Operations Forces (SOF) in Afghanistan.

Credit: created 2020 © artist Silvia Pecota



5 Serving the Nation’s Interests: Creating an Integrated and Agile Canadian Reserve Force



16 A Forensic Anthropologist’s Role in the Defence Team: Current Responsibilities and Future Opportunities within the Canadian Armed Forces

- 3 FROM THE EDITOR
4 LETTER TO THE EDITOR

PERSONNEL

- 5 **Serving the Nation’s Interests: Creating an Integrated and Agile Canadian Reserve Force**
by Shawn D. Bindon and Howard G. Coombs
- 16 **A Forensic Anthropologist’s Role in the Defence Team: Current Responsibilities and Future Opportunities within the Canadian Armed Forces**
by Sarah Lockyer

CIVIL-MILITARY RELATIONS

- 26 **Civil-Military Operational Support to the “Heart of Canada’s North”:
Looking to Alaska and the Australian North for Options?**
by Peter Kikkert and P. Whitney Lackenbauer

LEADERSHIP

- 41 **Deciphering the Roles of Chief Petty Officers/Chief Warrant Officers within
Command Teams**
by Necole Belanger

MILITARY HISTORY AND THEORIES OF WAR

- 51 **War is War: The Relevance and Practicality of The Principles of War for
Future Combat**
by Tim Gallant

VIEWS AND OPINIONS

- 61 **Emotional Intelligence: Leading through the COVID Crisis**
by Daniel Campbell
- 67 **Trained to Fight and Everything in Between**
by Bill Cummings

COMMENTARY

- 71 **The Aurora, the Cormorant and the Conundrums of Defence**
by Martin Shadwick

BOOK REVIEW

- 77 **Transforming Command: The Pursuit of Mission Command in the U.S.,
British and Israeli Armies**
Edited by Eitan Shamir
Reviewed by Peter J. Williams

Canadian Military Journal/Revue militaire canadienne is the official professional journal of the Canadian Armed Forces and the Department of National Defence. It is published quarterly under authority of the Minister of National Defence. Opinions expressed or implied in this publication are those of the author, and do not necessarily represent the views of the Department of National Defence, the Canadian Armed Forces, *Canadian Military Journal*, or any agency of the Government of Canada. Crown copyright is retained. Articles may be reproduced with permission of the Editor, on condition that appropriate credit is given to *Canadian Military Journal*. Each issue of the *Journal* is published simultaneously in print and electronic versions; it is available on the Internet at www.Canada.ca/canadian-military-journal.

ISSN 1492-465X



How to Contact Us

Canadian Military Journal
PO Box 17000, Station Forces
Kingston, Ontario
CANADA, K7K 7B4
E-mail: cmj.rmc@forces.gc.ca



28 **Civil-Military Operational Support to the “Heart of Canada’s North”:** Looking to Alaska and the Australian North for Options?



41 **Deciphering the Roles of Chief Petty Officers/Chief Warrant Officers within Command Teams**



61 **Emotional Intelligence: Leading through the COVID Crisis**

CANADIAN MILITARY JOURNAL

www.Canada.ca/canadian-military-journal

Editor-in-Chief

Christian Leuprecht
(613) 541-5010 ext. 6148
Christian.Leuprecht@forces.gc.ca

Publication Manager

Claire Chartrand
(613) 541-5010 ext. 6837
claire.chartrand@forces.gc.ca

Translation

Translation Bureau,
Public Services and Procurement Canada

Commentary

Martin Shadwick

Editorial Advisor

Michael Boire

Oversight Committee

Chairman

Major-General D. Craig Aitchison, Commander, Canadian Defence Academy (CDA)

Members

Christian Leuprecht, Editor-in-Chief,
Canadian Military Journal (CMJ)

Commodore Josée Kurtz, Commandant
Royal Military College of Canada (RMC)

Colonel Marty Cournoyer, representing
Chief of the Air Staff (CAS)

Major Chris Young, representing
Chief of Staff Army Strategy

Dr. H.J. Kowal, Principal,
Royal Military College of Canada (RMC)

Lieutenant-Colonel Brent Clute,
Director Canadian Forces Military Law Centre
(CFMLC), Canadian Defence Academy (CDA)

Captain (N) J. Jeffrey Hutchinson, representing
Chief of the Naval Staff (CNS)

Ms. Hanya Soliman, representing Chief of the
Defence Intelligence (CDI)

Editorial Board

Lieutenant-Colonel (ret'd) David L. Bashow

Professor Hamish Ion

Major (ret'd) Michael Boire

Philippe Lagassé

Dr. Andrea Charron

Lieutenant-Colonel (ret'd) David Last

Lieutenant-Colonel (ret'd) Douglas Delaney

Dr. Chris Madsen

Chief Petty Officer 1st Class Mike Dionne

Dr. Sean Maloney

Dr. Rocky J. Dwyer

Professor Brian McKercher

Lieutenant-Colonel (ret'd) Michael Goodspeed

Dr. Paul Mitchell

Major-General (ret'd) Daniel Gosselin

Dr. Nezhir Mrad

Major Tanya Grodzinski

Dr. Scot Robertson

Dr. David Hall

Professor Stéphane Roussel

Professor Michael Hennessy

Professor Elinor Sloan

Colonel (ret'd) Bernd Horn

Colonel (ret'd) Randall Wakelam

NOTE TO READERS

As a bilingual journal, readers should take note that where citations are translated from their original language, the abbreviation [TOQ] at the end of the note, which stands for “translation of original quote”, indicates to the readers that the original citation can be found in the published version of the Journal in the other official language.

FROM THE EDITOR

Welcome to the new-wind-in-the-sails edition of the *Canadian Military Journal*. David Bashow is retiring after 17 years at the helm of the flagship journal of the Canadian Armed Forces and the Department of National Defence. He not only expanded the readership that now includes 35,000 hits a month on the journal's web site from right across the globe, but also implemented many key yet less visible administrative changes, especially on the digital back-end, with the indispensable longstanding support of the many talents of Publication Manager Claire Chartrand. Looking at the polished final product, even I, with experience in publishing and on boards of journals and book series, am in awe of the effort, detail, and process that goes into producing four annual issues of the Journal, let alone in both official languages.

Never has the Journal been more important. The Canadian Armed Forces (CAF), and the many components of the Department of National Defence, may well be the most underappreciated and misunderstood organization in the Government-of-Canada family, and in the country. Never have fewer uniformed and civilian members had to take on a greater number and complexity of tasks with relatively fewer resources. During the Cold War, the CAF generally had a single principal mission: the Soviet Threat. During the 1990s, it evolved to a focus on peace-enforcement, and was followed by Canada's deployment to Afghanistan (2001–2014).

The complexity of today's operational frontage weighs on the CAF: maritime security, Arctic sovereignty, space, tactical cyber operations, special operations, and conceivably expanding into ballistic, hypersonic and unmanned underwater systems missile defence and/or nuclear deterrence – not to mention growing demands for domestic operations owing to climate change, such as wildfires and floods, as well as emerging highly disruptive hybrid and asymmetric threats from biosecurity, such as pandemics, to mis- and disinformation operations. Armed conflict has changed from attrition warfare to intellectual battles, from defeating the enemy on the battlefield to setting the conditions for stability and sustainable peace, from managing violence to overseeing national security, in collective defence and wars of choice alike. The Maritime, space and cyber domains especially are facing unprecedented competition and transformation.

Ergo, today's CAF are expected to contribute across a full spectrum of missions: prepare for large-scale conventional warfare; advise and assist in capacity building and training foreign troops against a host of terrorist non-state actors; take the lead as a framework country for NATO's Enhanced Forward Presence to deter the Russian revisionism in Latvia, and across the NATO's northeastern and southern flanks; contribute to UN peacekeeping/peacemaking operations; advance the Government of Canada's feminist international assistance policy through the Elsie Initiative on Women in Peace Operations; dispatch special operations forces to far-flung corners of the world to shore up local capacity,

prepare to deter violent extremists through expeditious response to threats to local and regional stability and deploy on shortest notice with allies to evacuate embassy staff, Canadian citizens, third-country citizens under very dangerous conditions; stand by to do more counter-piracy in the Gulf of Aden and elsewhere; provide a presence in the Arctic; support allies and partners by showing the flag in disputed waters in Asia; build world-class capability and capacity in a whole new domain in constant confrontation with state-based, state-supported and non-state bad actors who intentionally act below the threshold of NATO Article 5 and international law; and much more.

At the same time, much of the Department is focused on institutional and cultural change. As the single largest employee organization in the Government of Canada and in the country, the CAF has its work cut out to strive for, set and exceed the gold standard on professional culture and conduct. The dedicated women, men and diversity of those serving in uniform, across the Regular and Reserve Forces, along with civilians deserve nothing less. Old sergeants used to quip: "the CAF is here to defend democracy, not to practice it." Yet, the Huntingtonian conception of civil-military relations that is implicit in this claim is fundamentally flawed. The CAF serves Canadians: it projects force as much it projects values. Not only must the practices of a defence organization in a democracy align with the rules and values democracies claim to defend; but the standards of conduct must also meet the expectations of the citizenry.

This issue opens with Shawn Bindon and Howard Coombs, who make the case for achieving equality in the integration of the Reserves with the Regular Force. As the sole forensic anthropologist in the CAF, Sarah Lockyer's essay introduces the audience to some rather unique skillsets and capabilities that the CAF brings to bear for Canadians. Peter Kikkert and Whitney Lackenbauer detail comparative models for military engagement with northern community, from the United States and Australia, a point I have raised elsewhere previously when making the case for a small force component that would be dedicated to domestic operations. In honour and recognition of the resilience, commitment and contributions of the CAF, ongoing reviews and owing to the generous support of the RMC Class of 1965 for the Professor in Leadership that I currently hold, I am particularly encouraged by Necole Belanger's thoughtful reflection on NCOs. Tim Gallant draws our attention to the principles of warfare in the context of future combat, an issue that has become even more pertinent now that the US Joint Chiefs has acknowledged that the US armed services can no longer count on their traditional advantage of confronting the enemy head on with the benefit of overwhelming superiority in resources. Daniel Campbell provides insightful reflections on leadership during the pandemic and Bill Cummings opines on a debate on the spirit of those who serve. Finally, Martin Shadwick's commentary reminds us of the conundrums occasioned by aging military kit.

FROM THE EDITOR

Indeed, owing to fiscal constraints arising from the pandemic, both Canada and allies are unlikely to see a bigger military. But with demands growing in quantity and quality, the CAF can become an even better military. CMJ gives current and retired members, civilians, scholars and contributors from allied and partner countries a voice in key debates that have profound implications for us all. To this effect, my intent is to continue to diversify the nature of submissions and debates to be had while encouraging even greater

breadth, including original essays, poems and artwork to reflect on the CAF's role in national defence, international stability and human security: *Strong. Secure. Engaged.* If you have something to say or contribute, please reach out.

Christian Leuprecht
Editor-in-Chief, *Canadian Military Journal*
Class of 1965 Professor in Leadership, Royal Military College

LETTER TO THE EDITOR

Sir:

Major Chris Wattie's observations in the latest Review are refreshing. Someone should tell truth to power; he has done so.

Information Warfare has been waged for centuries. It can win battles, as Sun Tsu and others observed, and save lives. The Canadian government should learn from Major Wattie's article that you don't fight a gunman with a knife, and arm our foreign operations contingents accordingly.

In 1980, Colonel Nicholson related in the *Mobile Command Newsletter* a conversation he had with a young officer, who told him at the bar his entire Army career plan: staff training, college training, and staff postings. No mention was made of field training. Colonel Nicholson ended by asking, "Where are the tigers of yesteryear?"

Maybe a few still exist.

Charles Hooker
Major (Ret'd), Royal Canadian Corps of Signals

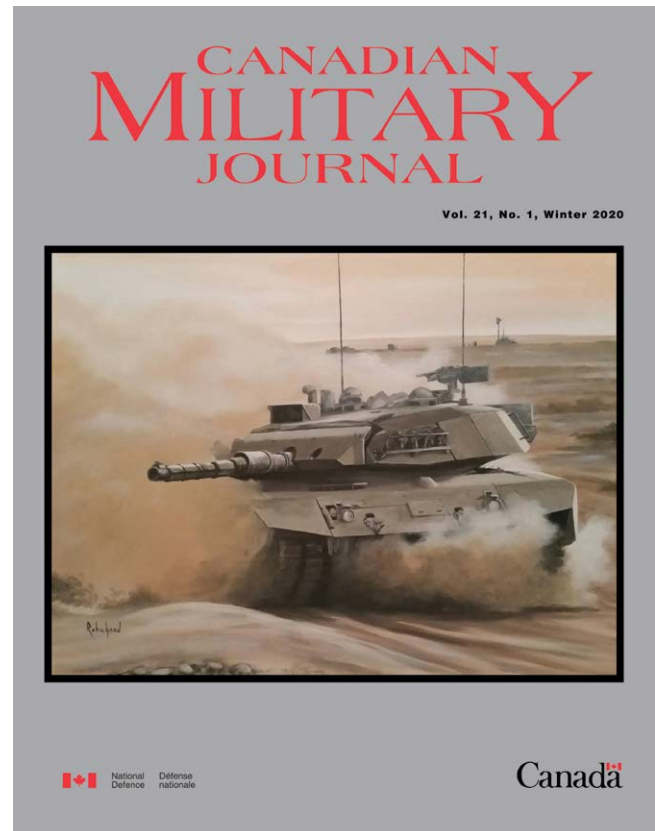



DND photo by Corporal Mark Schombs/PA03-2015-0217-005

Primary Reserve and Regular Forces artillery soldiers from the 4th Canadian Division on Exercise STALWART GUARDIAN board a Boeing CH-147 Chinook helicopter as part of the mortar insertion exercise at Garrison Petawawa, 19 August 2015.

Serving the Nation's Interests: Creating an Integrated and Agile Canadian Reserve Force

by Shawn D. Bindon and Howard G. Coombs

Brigadier-General Shawn D. Bindon, CD, MSc, is currently a full-time Reservist employed as the Director General (Deputy Chief) of Reserves and Employer Support at National Defence Headquarters. Bindon is a former brigade commander and defence attaché who has operationally deployed to Afghanistan and served in Bosnia-Herzegovina as a civilian. Bindon is currently coordinating efforts towards a “New Vision for the Reserve Force.”

Colonel Howard G. Coombs, OMM, CD, PhD, is a part-time Canadian Army Reservist who serves with the Office of the Chief of Reserves. In his civilian work he is an Associate Professor and the Associate Chair War Studies at the Royal Military College of Canada, in Kingston, Ontario. Coombs is a former brigade

commander who has operational deployments to Croatia, Bosnia-Herzegovina and twice to Afghanistan.

This policy enables the Reserve Force to achieve a fulltime capability through part-time service... The Reserve Force will receive new operational roles and will become further integrated into the total force. The Canadian Armed Forces will also create a more agile model that supports the transition between full- and part-time service that meets the needs of the member and the institution.

– Canada, Department of National Defence, *Strong, Secure, Engaged* (June 2017)¹

This succinct aspirational statement from Canada's 2017 defence policy *Strong, Secure, Engaged* (SSE) lays out the future vision for Canada's Reserve Force – an integrated and agile Reserve Force able to effectively and efficiently contrib-

ute to national security. This operational capability has three main components: (1) the service of part-time Reservists will produce full-time capability, (2) Reservists will be a cohesive and contributive part of the total force, and (3) sizable numbers of Reservists will be trained, readied, and equipped to take part in domestic or international operations, in many cases in areas where they may be the sole capability contributor. These elements, grouped in the defence policy under the unifying theme of “A New Vision for the Reserve Force,” will enable a Canadian Armed Forces (CAF) Reserve that contributes significantly to successful operational outputs. Canada's most recent defence policy directs enhanced integration between the Reserve and Regular forces to achieve this goal. Reserve *integration* is defined as achieving “full-time capability through part-time service.”²

Strong, Secure, Engaged lays out the actions that must be taken to enable this admirable goal of fundamental and (perhaps once in a lifetime) change. These measures include increasing numbers of Reservists, streamlining Reserve recruiting, capability, and force development leading to assigned roles that give full-time outcomes through part-time commitment, such as cyber operations, and enhancing existing Reserve contributions, like logistics, intelligence, and information operations. Also directed is the use of Reserve Forces in international capacity building operations, increasingly in a leading role. Along with enhanced use of Reserve Forces are accompanying policy initiatives like flexible terms of service, allowing seamless movement between Reserve and Regular service, plus alignment of pay and benefits between the two components. This is particularly significant in situations where the Reserve conditions of service are like that of a Regular. Additionally, there are ongoing changes to annuitant employment regulations to allow former Regulars who are in receipt of a pension greater flexibility for Reserve employment. Other incentives to Reserve service include full-time summer employment for the first four years of a Reservist's service and efforts to harmonize job protection legislation across Canada.

These endeavours have advanced at various rates since 2017, but despite the diligence, small successes, and the evident goodwill demonstrated by those involved in this work the path forward is not without debate. These conflicting views are in part due to varying understandings of integration. “A New Vision for the Reserve Force” sees a fully integrated CAF, bearing both a renewed operating environment and a cultural dynamic that looks to the Reserve Force as being able to mount, contribute, and, in limited cases, lead operations. What does this integration really mean? At times, there appears to be friction from differing perspectives of integrated organizations, some advocates promoting the diversity of complementary capabilities and others promoting some form of homogeneity as the best fashion in which to

leverage strengths of a varied group. Along with that is the method by which ideas of integration mesh with operational environments, domestic and international, as well as represent themselves in force generation, pre-deployment, deployment, employment, re-deployment and transition to future operations? These questions still require examination and introspection. From this, most important and reinforced from previous Canadian attempts in organizing the Reserves, is the need to clarify the challenges to Reserve/Regular cooperation that must be addressed to move forward in achieving the integration goals of *Strong, Secure, Engaged*.

“SSE lays out the actions that must be taken to enable this admirable goal of fundamental and (perhaps once in a lifetime) change.”

Time Flies Like an Arrow; Fruit Flies Like a Banana

The need for Reserve/Regular integration has underpinned the Militia and Reserve legacy in Canada. Historian George Stanley wrote in his well-known *Canada's Soldiers 1604–1954*: “The story of Canada's defence forces is as old as the history of Canada itself.”³ Stanley points out the early French colonists mustered when required to defend against possible attack. He also notes the inability of the French Regulars to adapt readily to the fighting conditions of New France or seemingly work in conjunction with the colonial Militia resulting in sub-optimal

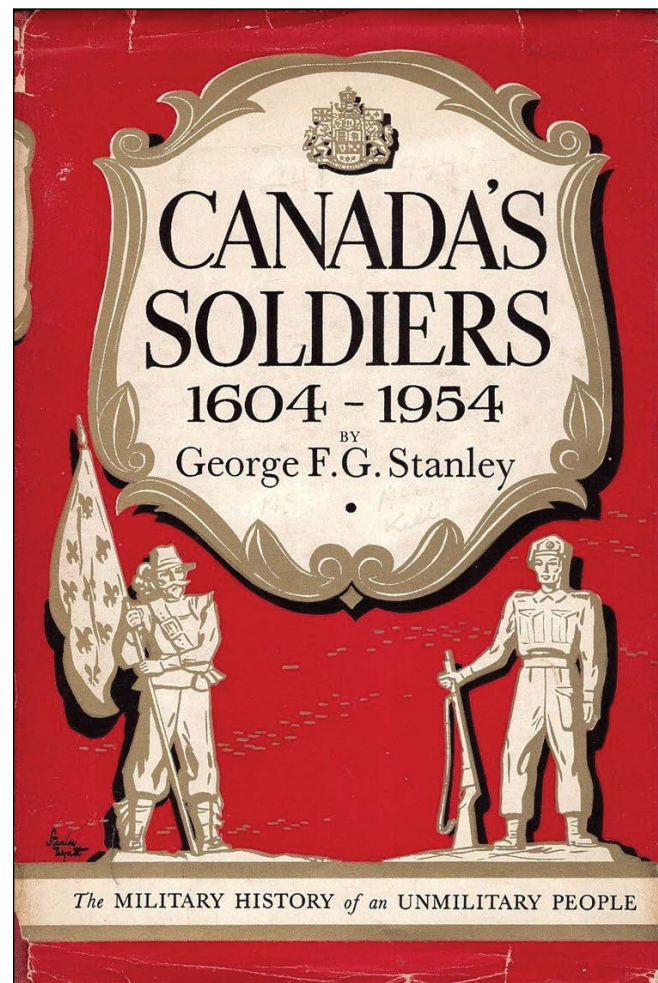

outcomes.⁴ In doing so, Stanley provides the earliest Canadian examples of the need for an effective combination of full- and part-time military forces. With the ebb and flow of time concepts of cooperation evolved with changing force structures. From the seventeenth until the late twentieth century the Militia⁵ provided the largest component of the Canada's defence forces, with the professional army providing support. If there was a need for mobilization the Militia could provide formed units, and as well contribute significantly to internal defence and security. At the same time, both the Royal Canadian Navy (RCN) and the Royal Canadian Air Force (RCAF) maintained Reserves from their early twentieth century inception, but they were much smaller entities than the Militia and from inception were meant to augment the full-time component of their respective services.⁶

“the need to clarify the challenges to Reserve/ Regular cooperation that must be addressed to move forward in achieving the integration goals of Strong, Secure, Engaged.”

However, in 1963 this perspective changed. The liberal government of Prime Minister Lester B. Pearson introduced a significantly reduced defence budget that would decrease the Militia from 51,000 to 30,000 effectives. Even the already small Naval and Air Reserve Forces did not escape significant cuts. As a result of these financial constraints, the RCN Reserve was decreased from 4,000 to 2,700 and the RCAF Reserve even more affected with a lessening of strength from 2,200 to 800. These financial directives were actualized for the Militia by the 1964 Suttie Commission, chaired by Brigadier Earl R. Suttie, Royal Canadian Artillery. The report of the commission realized the reduction of the Militia to the targeted figure of 30,000. This diminishment took on a life of its own and by 1972 the effective strength of the Militia had plummeted to 12,865. This restructuring, which eliminated 114 armories, effectively ended the belief that the Militia could provide any collective level of force generation for war and instead focused its raison d'être on individual augmentation to Regular units. At the same time, the Naval and Air Reserve had separate restructuring committees whose recommendations reinforced the goals of the defence budget. The Naval Reserve reorganization was achieved through eliminating, or “paying off,” auxiliary ships, closing and consolidating support infrastructure, and reducing or eliminating Naval divisions. At the same time, the Air Reserve became a six-squadron organization, with associated wing headquarters, all located at existing bases in order to take advantage of remaining infrastructure.⁷

In addition to a desire to rationalize defence expenditures were two major considerations that caused a diminution of Militia and Reserve capacity. First, the demands of the Cold War necessitated “forces in being” that could be deployed quickly. It was observed that Reserve Forces had lower training standards, resulting from less time to acquire skills. They were not always equipped similarly to the full-time military, and would require time to mobilize, equip, train, and deploy. As a result, their ability to contribute to no notice defence and security operations was believed questionable. Second, due to constantly changing elements of the strategic security environment, created by rapidly evolving technology,

proxy warfare, and changing governmental defence priorities, mainly budget driven, there was a consistent lack of coherent and enduring Canadian defence strategy linked to national goals and aspirations. The combination of these factors made the Reserves an opportune target for reductions and amalgamations. Former Defence Minister Paul Hellyer, in his memoir *Damn the Torpedoes*, alludes to these sentiments when describing the “painful” impact of defence cutbacks:

None was more so than the reduction in the reserves: but we had to save a few million here and a million or two there. None of us downgraded the reserves..., but we did have doubts about their cost-effectiveness. Many units were far below strength, and too many reservists were overfed World War II veterans whose age and physical condition would have

made it difficult for them to shape up in an emergency. Faced with the task of setting priorities, the Chiefs of Staff decided to conserve as much money as possible for the ‘forces in being’. It was a judgement call with which I fully concurred.⁸

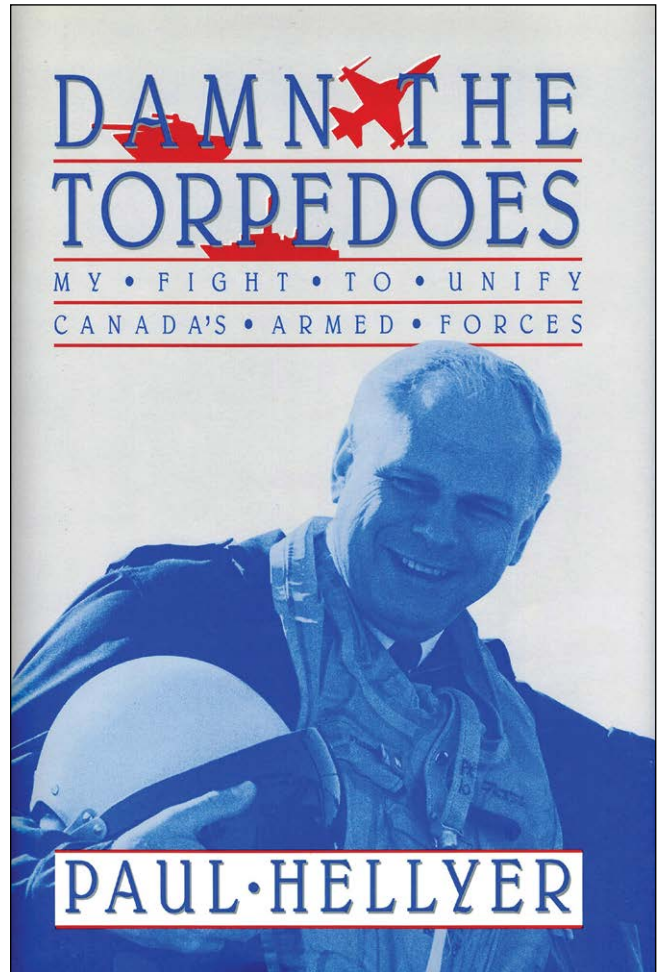

Hellyer's recollections include descriptions of acrimony displayed by Militia supporters and affected communities toward the Pearson government regarding the elimination of units and armories.⁹

The White Paper, *Defence in the 70s*, reinforced the viewpoints articulated in the reductions of 1963–1964 by stating the Reserves existed to support the Regular Force through augmentation and reinforcement, as well as potentially providing a mobilization base. They could assist with internal security contingencies and had some specialized tasks to address existing defence gaps. The Naval Reserve maintained a control of shipping organization that could be expanded if needed during a crisis, the Militia had trained personnel for civil emergencies, and the Air Reserve possessed some light air transportation capability. In 1973 the idea of a single force was advocated to not only use reserves as “back up support” for the Regular Force but as an integral part of the forces in being. The initiatives that commenced at that time were like that advocated by the 2017 policy *Strong, Secure, Engaged* with changes to pay and benefits, along with expanded reserve roles. However, the primary difference between then and now is that the focus was upon developing individuals and small groups with specialties that could supplement the Regular Force. This was augmentation of organizations not the integration of capability envisioned today.¹⁰ These changes continued with minor refinements until the 1980s.

“the primary difference between then and now is that the focus was upon developing individuals and small groups with specialties that could supplement the Regular Force. This was augmentation of organizations not the integration of capability envisioned today.”

In 1987, the White Paper *Challenge and Commitments* aimed to revitalize Canada's military, including the Reserve Force. Naval Reserve involvement with the Maritime Coastal Defence Vessel (MCDV) dates from this time. Also, the Air Reserve experienced greater responsibilities within, in what was then, Air Command.¹¹

However, it was the Militia that experienced the greatest change. Canada, like many countries in NATO, moved to a total force structure for the Land Forces. This meant, in some instances, that Regulars, as well as full- and part-time Reservists would serve in the same units. The Land Forces were also reorganized into four Land Force Areas: Western, Central, Quebec, and Atlantic.¹²

However, following the break-up of the Soviet Union and disintegration of the Warsaw Pact a new defence policy was created. The 1994 White Paper was shaped by a desire to reap the “peace dividend” resulting from the end of the Cold War. Reductions to the Reserves were again announced and a Special Commission to Examine the Restructuring of the Reserves was formed to look at the Primary and Supplementary Reserves. The reorganization of the Army Reserve from Districts to Canadian Brigade Groups was initiated during this time.

There were several Reserve reviews throughout this period from that of the Office of the Auditor General (OAG) in 1992 to the Special Commission on the Restructuring of the Reserves in 1995. The focus of the Special Commission's scrutiny was the part-time



Members of HMCS *Halifax* make their approach during a Naval Boarding Party exercise aboard HMCS *Halifax* with NATO ally FGS *Spessart*, a German Tanker during Operation REASSURANCE, 3 March 2021.



DND photo by Sergeant Daren Kraus/AR2010-0177-28

Master-Corporal Keven Gelinas, Royal 22^e Regiment provides security at the landing zone during Operation ATHENA, 9 July 2010.

soldiers of the Land Force Militia who were not perceived as meeting total force requirements. The other Reserve elements were seen to be achieving the objectives of the 1994 White Paper.¹³

Following from ministerial directed change initiatives of the late 1990s, the report *In Service of the Nation: Canada's Citizen Soldiers for the 21st Century*, was released in 2000. It was known as the Fraser Report, named after its chair, the Honorable John A. Fraser. In general, the Fraser Report noted issues with low training standards, burdensome administration, problems with recruiting processes, the lack of integration of the Reserves with the mobilization process, review of terms of service to bring in skilled applicants from the civilian economy who could fill specialized roles (like psychological operations or civil-military affairs), the need for reliable funding that is protected, and a requirement for an increase to the strength of the Reserves. Its recommendations resulted in a Chief of Defence Staff (CDS) directed project, the Land Force Reserve Restructure (LFRR). The observations of the Fraser Report were reinforced by the release of the Department of National Defence's *Shaping the Future of Canadian Defence: A Strategy for 2020*, that called for modernization of the Reserves. In addition to the Fraser Report and LFRR there were other Defence programs started at that time designed to grow the Reserves and provide better administrative structures to support them. Of note, in the context of today, was the International Policy Statement (IPS) released in 2005, which reinforced the necessity to increase the size of the Reserves. The IPS articulated the need for a mix of civilian and military specialist skills in the Reserves to react to domestic emergencies and augment Regular Force units with similar capabilities. A need to strengthen the Canadian Rangers for Arctic security and sovereignty was highlighted. Unfortunately, these goals were never fully realized.¹⁴

The *CDS Planning Guidance – Future of CF Reserves* promulgated in 2007 continued the trend towards creating “relevant and responsive” Reserve Forces. Simultaneously, Canadian participation in the NATO International Security Assistance Force (ISAF) mission in Afghanistan prompted a need for Reserves that could contribute to this ongoing international operation, support domestic operations, connect Canada's military to civilian communities and assist in the maintenance of sovereignty, especially in the North. Reviews from this time re-affirmed the requirement for a common recruiting system and similar training standards and called for a review of human resource and pay systems, as well as terms of service, to align them between Regular and Reserve Forces.¹⁵

Following on from this, was the *Report on Transformation*, or the *Leslie Report*, named after its chair, Lieutenant-General Andrew Leslie, released in 2011. The *Leslie Report* called for a return of full-time Reserve positions from headquarters and other locations to the part-time units and formations of the Reserve Forces to increase field force capacity. About the same time, the Vice Chief of Defence Staff's (VCDS) *Primary Reserve Employment Capability Study* (PRECS) Report of 2011, provided baseline figures for the Reserve Forces in the context of the ongoing transformation and other review efforts. The review included numbers for full- and part-time Reservists. PRECS also identified the need for Defence Administrative Orders and Directives (DAODs) pertaining to the Reserves, a requirement for a strategic concept for the Reserve Forces and need to ensure correct and guaranteed funding levels.¹⁶ Following that, several directives from both the CDS and VCDS provided guidance for initiatives aimed at creating a capable and responsive part-time Reserve that could support domestic and international operations.¹⁷



A Canadian soldier assigned to the Operational Mentoring and Liaison Team (OMLT) on sentry duty at a strongpoint operated jointly by Canadian and Afghan soldiers.

One of these initiatives was the 2015 Canadian Army initiative *Strengthening the Army Reserve* (StAR). StAR reinforced three main areas: growth, capability, and funding. First, growth included repatriation of recruiting responsibility to Reserve units, leadership initiatives and Regular Force personnel support. Second, capability included a rationalization of tasks, equipment and infrastructure. Last, funding was a promise to establish funding models to support these initiatives.¹⁸ These enhancements were not a moment too soon as the 2016 Office of the Auditor General Report reviewing the Canadian Army Reserve portrayed a force in disarray. These changes are ongoing and were incorporated in the 2017 *Strong, Secure, Engaged*.¹⁹

For Want of a Nail

In retrospect, apart from the most recent StAR initiative these efforts were not able to establish a cooperative, more integrated Reserve/Regular Force. The issues contributing to this lack of success were manifold and ranged from a lack of strategic clarity in the visualization and implementation of these initiatives through ambitious expectations of the abilities of Reserve Forces to meet the demands that were place upon

“Strengthening the Army Reserve (StAR) reinforced three main areas: growth, capability, and funding.”

them. Resultantly, Regular perspectives of Reservists that are cynical as to actual capability have arisen over the decades.

These views can be generally stated as members of Reserve Forces are sometimes regarded as civilians in uniform, lacking commitment, expertise, and legitimacy. At the same time Reservists sometimes see Regulars as unimaginative and unable to interact with the civilian population, as well as being willing to use Reservists and their service when needed but ready to disregard them when that necessity has passed. Or even worse use the Reserves as a source of funding, equipment, and people to the detriment of the long-term viability of Reserve units.²⁰ These perceptions, rooted in historical experience, real and imagined, impede harmonization of our efforts towards the integration envisioned in our most recent defence policy. Even the large Reserve contribution to international deployments to the Balkans and Afghanistan, as well as sudden domestic operations, like ice storms, floods, firefighting, and other crises which have demonstrated the capacity of the Reserve Forces over the last 30 years, have not eliminated these deeply entrenched sentiments. A senior Army Reservist, Brigadier-General (Retired) James Camsell, when reflecting on his service as a Lieutenant-Colonel, in

Afghanistan in 2008 with the Operational Mentoring and Liaison Team (OMLT) in Kandahar opined:

I was in training in New Mexico and I volunteered to become an infantryman [with the OMLT], nobody knew I was a reservist, most people did not know I was a reservist. So I remember I was having a coffee with some RCR dudes and they started talking about cartoons. So they call reservists cartoons in the RCR, because you're only there on Saturdays type thing. So I listened to this, and they didn't know who I was and I said 'hey, you realize that I'm a reservist and half this section is reserve?'

BGen Camsell also recounts several incidents in Kandahar in which reservists were not perceived as being professionally competent, despite stellar performance, or receiving lesser treatment than the Regulars they served alongside, all of which he attributes to the fact that they were Reservists.²¹ While one would hope that these perspectives do not reflect current thought, but with the passage of time the acknowledgement of the Reserve Force contributions during the last decades will diminish and these negative attitudes may re-assert themselves to act as barriers to Reserve/Regular integration.

Articulating the New Vision for Canada's Reserve Force²²

To institutionalize the ideas contained in Canada's *Strong, Secure, Engaged*, one must confront all biases. Understanding what Canada's Reserve Force is, and is not, becomes crucially important. The Primary Reserve consists of (1) Naval – around 4,000 personnel in 24 cities; (2) Army – about 19,000 reservists distributed in 185 units across 86 cities; (3) Air Force – approximately 2,000 reservists spread nationally in RCAF total force establishments; (4) Military Personnel Command, which includes Canadian Forces Health Services Reserve – 16 units across Canada and the one Canadian Field Hospital in Ottawa – and the National Defence Headquarters Primary Reserve List (PRL) – the latter with roughly 1,500 members; (5) Special Operations Command personnel; and (6) Judge Advocate General Reserve – almost 60 legal officers. Each element is responsible to a service command and can conduct or augment various operations with varying degrees of notice depending on whether it is domestic or international. Along with the ability to respond to these demands, the Reserve Force provides the CAF connection to Canadian communities and emphasizes citizenship through



DND photo by Corporal Shilo Adamson/IS2010-3012-02

A Canadian Ranger rides on a Light Over Snow Vehicle while at a bivouac on Oopik Island, near Canadian Forces Station Alert during Operation NUNALIVUT.

service to country.²³ Then, the Canadian Rangers (a sub-component of the Reserve Force who form part of the Canadian Army) give the only continuous CAF presence in many remote and Arctic communities, and can provide surveillance, community support, search and rescue and patrol support. Additionally, a Supplementary Reserve currently consists of about 6,700 inactive or retired members of the CAF, Regular or Reserve, who are willing and could be available for service until age 60. There is a five-year limit on retention due to “skill fade.” Finally, the Cadet Organizations Administration and Training Service (COATS) consists of officers and non-commissioned members who conduct training, supervise, and administer the Canadian Cadet or Junior Canadian Ranger movement.²⁴ Terms of service for each of these sub-components vary. Although the *National Defence Act* contains provisions to employ any or all these sub-components on operations, it is the Primary Reserve that is the source of personnel for deployments, although the Canadian Rangers are increasingly used in support of CAF operations in their local areas.²⁵

Reservists are distributed in hundreds of communities across Canada. Most of these individuals hold civilian employment or attend an educational institution. Because of this demographic, part-time Reservist availability for military service depends upon many elements, like defence policy; federal, provincial, and territorial legislation; plus socio-economic aspects, like the help and support of their family, their community, and their employer.²⁶ Of note, except when voluntarily participating in operations designated by the CDS, Reservists are not subject to the unlimited liability of their Regular counterparts. Nevertheless, over the course of their service, Reservists will be asked to commit to deployments at home and abroad, as well as undergo substantial professional education and training. Absences from home for these obligations are significant, often using vacation leave from work at the expense of family time. Military administration, training, and education are, then, only a few of the aspects of the support required for effective Reserve Forces. If Reservists cannot access military support and community backing – which includes their civilian employer and family – to mitigate the demands produced by their reserve commitment, the force generation of Reserves to create full-time operational capacity for operations will not be successful. That is why Canada’s 2017 defence policy stresses that integration is underpinned by the need to “...allow Reservists to balance a vibrant civilian life and occupation with meaningful, part-time military service while enhancing the overall Canadian Armed Forces effectiveness.”²⁷

“Integration instead is a whole of defence approach to how Reserve capability is generated and employed to achieve integrated effects.”

Consequently, what does integration really mean in the context of *Strong, Secure, Engaged*? What does it not mean? Integration is not solely about augmentation, or increasing the numbers, of Reservists in Regular organizations. That has already been attempted. Integration instead is a whole of defence approach to how Reserve capability is generated and employed to achieve integrated effects. Integration is the creation of the total defence force that should incorporate all elements of organizational development including doctrine, structures, training, education, materiel, equipment, management, leadership, and command, as well as infrastructure.

Simplistically put, the “we” and “them” perspective that seems to be at times present in conscious and unconscious bias needs to be eliminated. Rather than disparate elements Reserves should be viewed as one joint component for which planning occurs in parallel with their Regular counterparts. Although force generation and employment models may be different the idea of creating integrated effects remains unchanged. For example, there should be no “Regular Force equipment and Reserve Force equipment” or “Regular Force infrastructure and Reserve Force infrastructure” but simply CAF equipment and CAF infrastructure with usage integrated into holistic CAF needs.

Critical in all of this is that true integration will occur when the only difference across the Department of National Defence is terms of service, or employment. Importantly this means a unified one CAF perspective on compensation, benefits, and administration and their associated policies – remuneration, access to services/benefits, application of the *National Defence Act* and Queen’s Regulation and Orders, on top of other applicable policies, directives or instructions. Significantly, this has proved the most difficult challenge to resolve, and is the most important. Major-General (Retired) Herb Petras, a former Chief of Reserves, indicated that this change, particularly unified terms of service, which has been advocated since the early 2007, is the most crucial and difficult to affect.²⁸

Perhaps the main barrier to effective integration is managing the process by which change will be affected. Efforts cannot be simply focused on adjustments to the CAF structure by adding people and money. Structural additions or streamlining have failed to create integration in the past. Confronting the ingrained historical legacy of previous attempts to optimize the usage of Reserves and the biases that have evolved from them is the first step. Following from that, visualizing the integrated effects required from Reserve/Regular alignment and the terms of service is needed along with the policy framework required to support it, and from

that flowing into the structural organization needed to produce integrated activities. Changing our primary focus from tailoring our organizations to creating effective policy first is the only way to avoid the pitfalls of the past. Frankly put, without supporting and effective terms of service, aligned administration, compensation, and benefits, one cannot move beyond re-imagining organizations and roles all within similar or the same constraints as the last 60 years. Otherwise despite much effort we might as well be “moving the deck chairs on the Titanic” and this will be another fruitless round of Reserve/Regular engagement.

Conclusion

We have a significant and perhaps fleeting opportunity to integrate the CAF and we need to seize this moment. This is truly a once in a generation opportunity.

It is apparent, in the myriad of shifts regarding full- and part-time military force cooperation and integration that have taken place in Canada | move from ideas of individual or collective augmentation to

since 1960s unification, there was and is a perception of “many paths to the same destination.” However, the numerous and constant adjustments to organizations and roles have had an adverse impact on the elements of the Canadian Armed Forces Reserve. Also, and importantly in the context of defence management, these continual course changes have not permitted any meaningful progress towards a mutually reinforcing concept of Reserve/Regular cooperation. While consensus exists about the need for Reservists and Regulars to serve together with common vision and mutually accepted outcomes, the “how” that is to be attained diverges in detail and methodology depending on whom is engaged. Clarity on this aspect of the integration goal directed by *Strong, Secure, Engaged* needs to be attained.

One should start with the acknowledgement that Reserve (and Regular) Forces are different from popular conceptualizations and ingrained beliefs. Perspectives need to

“without supporting and effective terms of service, aligned administration, compensation, and benefits, one cannot move beyond re-imagining organizations and roles all within similar or the same constraints as the last 60 years.”



Major-General Herb Petras, Chief of Reserves and Cadets during his Change of Appointment Ceremony at the National Defence Headquarters, 20 May 2008.

DND photo SU2008-0208-05

creating successful integrated effects through complementary skills. Along with that is the imperative to facilitate balance amongst the Reserve triad of military service – family – employer through an effective policy framework. This is the starting point to any real and lasting efficacy.

In the final analysis, integration is currently viewed in a variety of ways by the different members of the defence team.²⁹ It can be argued that in most cases, integration is perceived as pertaining to building Reserve/Regular organizations, as well as a concentration on individual augmentation, not towards creating collective capabilities and their management to producing integrated effects. While integration needs to be about producing and employing amalgamated capability, the current focus is upon force structure. We need to shift this

“While integration needs to be about producing and employing amalgamated capability, the current focus is upon force structure. We need to shift this perspective to create a unified vision of Canadian Armed Forces integration that optimizes the contributions of all its members both full- and part-time to achieve unified Reserve/Regular effects in the international and domestic security environments.”

perspective to create a unified vision of Canadian Armed Forces integration that optimizes the contributions of all its members both full- and part-time to achieve unified Reserve/Regular effects in the international and domestic security environments.

Acknowledgment

We would like to express our gratitude for the advice and input of Colonel Patrick Kelly, MSM, CD, Deputy Chief of Staff Operations Military Personnel Command and Colonel James McKay, CD, PhD, Assistant Chief of Staff Support 4th Canadian Division, and former Honorary Colonel John Selkirk, CD, Brockville Rifles. As always, all remaining errors are ours alone.



A reservist from 38 Brigade Group's Influence Activities Company conducts patrols and executes key leader engagements during Exercise MAPLE RESOLVE 19, 11 May 2019.

DND photo W707-2019-0013-005 by Private Jordyn Anderson

NOTES

- 1 Canada, Department of National Defence, *Strong, Secure, Engaged: Canada's Defence Policy* (June 2017), p. 16. Retrieved at <http://dgpapp.forces.gc.ca/en/canada-defence-policy/docs/canada-defence-policy-report.pdf>.
- 2 Department of National Defence, *Strong, Secure, Engaged*, pp. 67–68.
- 3 George F. G. Stanley, *Canada's Soldiers: The Military History of an Unmilitary People* (Toronto: The Macmillan Company of Canada Limited, 1960), p. 4.
- 4 Stanley, *Canada's Soldiers*, pp. 16–18.
- 5 Today's Canadian Army Reserve.
- 6 See Richard H. Gimblett and Michael L. Hadley, *Citizen Sailors: Chronicles of Canada's Naval Reserve 1910–2010* (Toronto: Dundurn Press, 2010); Peter Kasurak, *A National Force: The Evolution of Canada's Army, 1950–2000* (Vancouver and Toronto: University of British Columbia Press, 2013); Sandy Babcock, *Withered on the Vine: The Postwar RCAF Auxiliary* in Yves Tremblay, ed., *Canadian Military History Since the 17th Century: Proceeding of the Canadian Military History Conference, Ottawa, 5–9 May 2000* (Ottawa: Department of National Defence, Directorate of Heritage of History, 2001), 395–404; and, T. C. Willet, *Canada's Militia: A Heritage at Risk* (Ottawa: Conference of Defence Associations Institute, 1990), pp. 79–92.
- 7 T. C. Willet, *Canada's Militia: A Heritage at Risk* (Ottawa: Conference of Defence Associations Institute, 1990), 79–92; and Paul Hellyer, *Damn the Torpedoes: My Fight to Unify Canada's Armed Forces* (Toronto: McClelland and Stewart, Inc., 1990), pp. 101–102.
- 8 Hellyer, *Damn the Torpedoes*, p. 102.
- 9 Hellyer, *Damn the Torpedoes*, pp. 102–105.
- 10 Canada, Government of Canada, Department of National Defence, *White Paper on Defence* (Ottawa: Information Canada, 1971), 45–46; Canada, Government of Canada, Department of National Defence, *Defence 1973* (Ottawa: Information Canada, 1974), pp. 59–65; and Canada, Government of Canada, Department of National Defence, *Defence 1979* (Hull: Canadian Government Publishing Centre, 1980), p. 28.
- 11 The pre-unification names of the three services were restored in 2011.
- 12 The Land Force Areas were renamed Divisions in 2013 but keep a regional structure.
- 13 Michel Rossignol, *MR-138E The Reserve Force of the Canadian Forces: Restructuring Process*, (Ottawa: Government of Canada, Parliamentary Research Branch, Political and Social Affairs Division, 10 May 1996); retrieved at <http://publications.gc.ca/Collection-R/LoPBdP/MR/mr138-e.htm>; and, Corinne McDonald, *PRB 99-11E The Canadian Armed Forces: The Role of the Reserves*, (Ottawa: Government of Canada, Parliamentary Research Branch, Political and Social Affairs Division, 29 November 1999); retrieved at <http://publications.gc.ca/collections/Collection-R/LoPBdP/PRB/prb9911-e.htm>.
- 14 See Canada, Department of National Defence, *Press Release: Defence Minister Welcomes Final Report of the Minister's Monitoring Committee on Change* (9 February 2000); retrieved at <http://www.forces.gc.ca/en/news/article.page?doc=defence-minister-welcomes-final-report-of-the-minister-s-monitoring-committee-onchange/hnm18xj>; Canada, Department of National Defence, *Press Release: Minister Of National Defence Welcomes Report* (6 June 2000); retrieved at <http://www.forces.gc.ca/en/news/article.page?doc=minister-of-national-defence-welcomes-report/hnm18zl>; Canada, Department of National Defence, *Press Release: Government Policy for Army Reserve Restructure Unveiled* (12 October 2000); retrieved at <http://www.forces.gc.ca/en/news/article.page?doc=government-policy-for-army-reserve-restructure-unveiled/hnm18x3>; Dr. Richard Weitz, *The Reserve Policies of Nations: A Comparative Analysis* (Carlisle, Pennsylvania: U.S. Army War College Strategic Studies Institute, 17 September 2007); retrieved at <http://www.strategicstudiesinstitute.army.mil/pubs/display.cfm?pubID=786>; Canada, Department of National Defence, *Government of Canada Policy Statement Land Force Reserve Restructure (LFRR) Policy Statement* (12 October 2000); Canada, Department of National Defence, *Force Reserve Restructure (LFRR) Strategic Plan: Executive Summary* (September 2000); and Canada, Department of National Defence, *Force Reserve Restructure (LFRR) Strategic Plan* (September 2000).
- 15 See Canada, Department of National Defence, *CDS Planning Guidance Future of CF Reserves* (12 June 2007) and the presentation by Major-General Herb Petras, *Canadian Forces Reserves: Transformation A Strategic View* (2008).
- 16 See Canada, Department of National Defence, *Report on Transformation* (2011); retrieved at http://mldc.whs.mil/public/docs/library/allportfolios/Canadian_Report-Military_Transformation-2011.pdf; and Canada, Department of National Defence, Vice Chief of Defence Staff, 1900-1 (CFD) *Primary Reserve Employment Capability Study (PRECS) Report* (April 2012).
- 17 Canada, Department of National Defence, *Chief of Defence Staff Guidance to the Canadian Armed Forces* (April 2015); and Canada, Department of National Defence, 1052-4-02 (C Res & Cds) *CDS Initiating Directive Reserve Strategy 2015: Strengthening the Primary Reserve* (9 October 2015).
- 18 Canadian Army resourcing for all these initiatives has not yet been baselined funded. Email dated 3 May 2021 5:07 PM.
- 19 For more information on individual lines of effort see Canada, Government of Canada, National Defence, *Strengthening the Army Reserve*; retrieved at <https://www.army.gc.ca/en/star/index.page>; and Canada, Government of Canada, Office of the Auditor General, *Report 5—Canadian Army Reserve—National Defence*; retrieved at https://www.oag-bvg.gc.ca/internet/English/parl_oag_201602_05_e_41249.html.
- 20 These ideas arise from research presented during the *Total Defence Force Online Workshop*, 06/07 May 2021.
- 21 Brigadier-General (Retired) James Camsell, OMM, MSM, CD, interview by Officer-Cadet Dennis Emerson, St. John's, Newfoundland, 20 February 2021.
- 22 See *A New Vision for the Reserve Force* in Canada, Department of National Defence, *Strong, Secure, Engaged: Canada's Defence Policy* (June 2017), pp. 67–70; retrieved at <http://dgpapp.forces.gc.ca/en/canada-defence-policy/docs/canada-defence-policy-report.pdf>.
- 23 Significantly, 97% of Canadians live within a 45-minute drive of a Reserve Force unit. *A New Vision for the Reserve Force* in Canada, Department of National Defence, *Strong, Secure, Engaged: Canada's Defence Policy* (June 2017), p. 67.; retrieved at <http://dgpapp.forces.gc.ca/en/canada-defence-policy/docs/canada-defence-policy-report.pdf>.
- 24 For the purposes of this examination of Canada's Reserve Forces and contributions to national security, COATs will not be considered. See Canada, Government of Canada, Office of the National Defence and Canadian Armed Forces Ombudsman, *The Reserve Force* (Date modified: 2020-11-25); retrieved at <https://www.canada.ca/en/ombudsman-national-defence-forces/education-information/caf-members/career/reserves/reservists.html>.
- 25 Canada, Government of Canada, Office of the National Defence and Canadian Armed Forces Ombudsman, *The Reserve Force* (Date modified: 2020-11-25); retrieved at <https://www.canada.ca/en/ombudsman-national-defence-forces/education-information/caf-members/career/reserves/reservists.html>.
- 26 Canadian Armed Forces 101 (Date modified: 2021-03-11); retrieved at <https://www.canada.ca/en/department-national-defence/corporate/reports-publications/transition-materials/defence-101/2020/03/defence-101/caf-101.html>; and Enclosure to NATO, North Atlantic Military Committee, Secretary General, *Military Decision on MC 441/2 NATO Framework Policy on Reserves* (19 January 2012), paras 3 and 4.
- 27 Canada, Department of National Defence, *Strong, Secure, Engaged: Canada's Defence Policy* (June 2017), p. 68; retrieved at <http://dgpapp.forces.gc.ca/en/canada-defence-policy/docs/canada-defence-policy-report.pdf>.
- 28 Presentation by Major-General Herb Petras, *Canadian Forces Reserves: Transformation A Strategic View* (2008).
- 29 “The Defence Team is composed of military personnel in the Canadian Armed Forces and civilian personnel in the Department of National Defence who work together to carry out the defence mandate.” Lise Arseneau and Amy Cameron, *The Composition of the Defence Team*, in Irina Goldenberg, Angela R. Febraro and Waylon H. Dean, eds., *The Defence Team: Military and Civilian Partnership in the Canadian Armed Forces and the Department of National Defence* (Kingston: Canadian Defence Academy Press, 2015), p. 69.



Sergeant Yannick Bédard, imagery technician for Canadian Forces Combat Camera, snaps photos of the ruins in a historic district during a reconnaissance patrol carried out by the DART Civil-Military Cooperation team as part of the Government of Canada's earthquake relief efforts in Nepal, 4 May 2015.

A Forensic Anthropologist's Role in the Defence Team: Current Responsibilities and Future Opportunities within the Canadian Armed Forces

by Sarah Lockyer

Sarah Lockyer, PhD, is currently a Casualty Identification Coordinator in the Directorate of History and Heritage under Military Personnel Command. She has a BSc in Anthropology, a MSc in Forensic Archaeological Science, and a PhD in Bioarchaeology.

In August 2016, I began working for the Canadian Armed Forces as its Casualty Identification Coordinator. For me, this is a dream job; an opportunity to use my education on a full-time basis. My position is located within the Directorate of History and Heritage¹—its mandate includes the preservation and communication of Canada's military history to foster pride in its heritage—under Military Personnel Command.² One of the first things my manager at the time asked me to do was to increase awareness of the Casualty Identification Program, both within and outside National Defence. Since that time, I have met many members of the Defence Team at various ranks and civilian levels. At almost every opportunity, I try to talk about the Casualty Identification Program, its mandate, and my role as its forensic

anthropologist. Often, I am met with blank stares, questioning looks, complete confusion, or “that’s so cool!” Honestly, I expect the looks of confusion and I am not the least bothered by it as it provides an opportunity to talk about the interesting stuff I get to do. But it does lead to the questions of what is a Casualty Identification Coordinator and why does a forensic anthropologist work for Canadian Armed Forces?

A forensic anthropologist has skills and knowledge that are focused on the human skeleton and its 206 bones (when a person has reached adulthood). The forensic anthropologist can determine if bones are human or not and, subsequently, analyze the human skeletal remains to create a biological profile of the individual which will hopefully lead to their identification. The skeleton can reveal a great deal of information about that person and their life. Analyzing a skeleton may reveal a person's age-at-death, their height, their sex, whether they broke any bones during their lifetime, their diet, any diseases they may have had during their lifetime, amongst other biological and environmental factors.³



Everett Collection Historical/Alamy Stock Photo

Workers at the Fresh Kills Landfill gather debris from the World Trade Center for victim identification and evidence.

This skillset has proven to be useful for medical examiners' and coroners' offices when human remains have been discovered and need to be identified. The anthropologist can also provide advice on any injuries appearing on the bone which can assist the medical examiner or coroner determine cause and manner of death. As examples, there are anthropologists working for the New York City Office of the Chief Medical Examiner, who continue to analyze and identify the remains of the victims of the World Trade Center disaster, amongst other responsibilities.⁴ The Colibrí Center for Human Rights, within the Pima County Office of the Medical Examiner in Arizona, USA, where the remains of migrants from Central and South American countries are frequently discovered near the border with Mexico and need to be identified, also seek the skills of a forensic anthropologist.⁵ Forensic anthropologists are also employed with organizations such as the International Commission on Missing Persons and the International Committee of the Red Cross. The International Commission on Missing Persons was created in 1996 as a response to the large number of individuals who went missing during the 1991–1995 fighting in the former Yugoslavia. Since then, it has expanded internationally and provides identification services related to conflicts or environmental disasters in Iraq, Colombia, Libya, the United States and elsewhere.⁶ Forensic anthropologists and archaeologists can be vital in the investigation

“As Casualty Identification Coordinator, I manage the investigations into the identity of newly discovered skeletal remains of Canadian soldiers who were killed in action”

of war crimes by locating and excavating mass graves, collecting evidence which could be used in a court of law, and identifying the remains of those buried within said mass graves. This has been evident in the proceedings of the International Criminal Tribunal for Rwanda⁷ and the International Criminal Tribunal for the former Yugoslavia.⁸

The above may bring you right back to the initial question: why? Why are these skills needed within the Canadian Armed Forces? As Casualty Identification Coordinator, I manage the investigations into the identity of newly discovered skeletal remains of Canadian soldiers who were killed in action during the First and Second World Wars, as well as the Korean conflict. Alongside the coordination of all the steps that can be part of an investigation, one of my main responsibilities is related to the anthropological analysis of the skeletal human remains. This article will describe my role as a forensic anthropologist within the Defence Team and how my skills and knowledge can be further applied to some of the Canadian Armed Forces' business. The first section will delve deeper into the Casualty Identification Program, its mandate, responsibilities, and how we are able to identify soldiers who were killed in action more than 100 years ago. The second section will explore the role a forensic anthropologist can have during Disaster Victim Identification and how it can complement the skills and expertise



The Canadian Forces Forensic Odontology Response Team during the Bureau of Legal Dentistry (BOLD) Disaster Victim Identification training in 2018 at the University of British Columbia.

of the Canadian Forces Forensic Odontology Response Team. The final section will explore the benefit of having a Mass Fatality Response Plan and how a forensic anthropologist can help formulate it.

The Casualty Identification Program

In 2003, two sets of human skeletal remains were found in France and thought to be Canadian soldiers of the First World War due to the artefacts associated with the remains. As technology, especially DNA, had become much more accessible, the Directorate of History and Heritage decided that a full investigation into the identity of these remains would be undertaken. The investigation was successful and both soldiers were buried with their name in a cemetery close to where they fell. This led to the formal creation of the Casualty Identification Program⁹ in 2007 within the Directorate of History and Heritage.

“Through extensive historical research, it is sometimes possible to identify the soldiers who have already been buried under an “unknown” headstone. The Casualty Identification Program is responsible for adjudicating such research and confirming the identification.”

There are more than 27,000 Canadian soldiers and airmen from the First World War, the Second World War, and the Korean conflict who have no known grave. About 20,000 of those service members are from the First World War, more than 7,000 from the Second World War, and 16 from the Korean conflict. As they have no known grave, they are commemorated on memorials such as the Canadian National Vimy Memorial in Vimy, France. We do believe that many of these soldiers and airmen are already properly buried under a Commonwealth War Graves Commission¹⁰ headstone as Unknown Soldiers or Unknown Canadian soldiers. However, as the nationality is not always commemorated on the headstone if it was not known at the time of burial, it is impossible to have an exact count of how many Canadian soldiers and airmen are properly buried and how many are not. Through extensive historical research, it is sometimes possible to identify the soldiers who have already been buried under an “unknown” headstone. The

Casualty Identification Program is responsible for adjudicating such research and confirming the identification.

Every year, due to modern human activity such as construction and farming, skeletal human remains of soldiers and airmen of various nationalities are discovered, especially in France and Belgium. Canada has seen five to ten discoveries per year since I began working as Casualty Identification Coordinator in 2016. The program’s mandate is to respond to such discoveries when the remains are thought to be Canadian—either due to the associated artefacts that display “Canada” or a Canadian unit, and/or due to the location of the discovery with associated Commonwealth artefacts—and make every effort to identify the remains so that they are buried with their name, by their regiment, and in the presence of family.

The first step when remains are found is a historical analysis of the location of recovery. The analysis is undertaken by historians within the Directorate of History and Heritage and will determine who (i.e., regiments and individuals) was in the area during the war and who from that list was recorded as having no known grave following the war. If regimental artefacts are found to be associated to the remains, this provides a likely focus for our investigation. The presence of artefacts can at times take a list of 49 missing soldiers and immediately reduce it to seven, ensuring that a successful outcome is that much more

within reach. Once it has been determined which units were in the area and how many soldiers were killed in action but have no known grave, the list of potential candidates can still be quite large.

My anthropological analysis of the remains is done using methods established in the field of anthropology which I use to create a biological profile of the individual. A typical biological

“In the case of the Casualty Identification Program, the two key pieces from the biological profile are age and height as they are recorded in the Attestation Paper and Medical Sheets found in the soldiers’ personnel files.”

profile seeks to estimate the following biological data: age, sex, ancestry, height, trauma, and pathology. In the case of the Casualty Identification Program, the two key pieces from the biological profile are age and height as they are recorded in the Attestation Paper and Medical Sheets found in the soldiers’ personnel files. The list of potential candidates created following the historical analysis can then be narrowed down once again to soldiers who correspond to the age and height ranges derived from the remains—always keeping in mind that some lied about their age to enlist. This will likely provide a list of candidates that is much smaller so that the soldiers’ family histories can be researched, hopefully leading to a living and viable DNA donor. At times, the information derived from the anthropological analysis of the remains can reduce the list

of potential candidates to a handful which highly increases the chances of the remains being identified.



ronslak/Alamy Stock Photo

Scientist in lab collects a DNA sample in a test tube with a cotton swab.

You may be asking yourself “Why not just use DNA? Surely if you have the DNA from the remains, you can identify the individual.” Theoretically yes, but unless there is a DNA sample from a living relative that can be compared to the DNA sample from the remains, the sample from the remains alone does not yield much information. Remember that if we are investigating the identity of remains from the First World War, the initial list of potential candidates is approximately 20,000. To optimize the DNA sample from the remains, the list of potential candidates must be narrowed down as much as possible. DNA is a fantastic tool for identification purposes, but it does have limitations that are important to consider. There are different types of DNA; some survive better in older remains than others. The condition of the remains, which can range from excellent to poorly preserved, may affect the type and usability of the DNA that is extracted. This will at times force the investigation down a path if a type of DNA is found to be “not suitable for comparison.” It is also important to remember that the family members who are donating their DNA can be quite a few generations removed from the soldier as immediate family members have died, especially for soldiers who died more than 100 years ago. Sadly, it does also happen that there are no more living donors who are related to a specific soldier. Therefore, some soldiers do not have a family reference sample that can be compared to the skeletal remains.

“If the DNA results establish a familial link, the final step in the investigation is to present the case to the Casualty Identification Review Board.”

Following extensive genealogical research to find specific relatives who are viable DNA donors—based on the type of DNA extracted from the bone—and willing to donate a sample, DNA testing is done to determine if there is a familial link between the remains and the DNA donor. If the DNA results establish a familial link, the final step in the investigation is to present the case to the Casualty Identification Review Board. As the forensic anthropologist for the program, I write a 20–30+ page report, which is peer-reviewed by an outside anthropologist at the Canadian Museum of History to make sure the methods were properly applied and that my reasoning is sound. The report details the anthropological analysis of the remains and makes a recommendation for identification or for burial as an Unknown Soldier. Board members

include both civilian and military staff from the Directorate of History and Heritage and members from the Canadian Forces Forensic Odontology Response Team. The outside anthropologist and representatives from Commonwealth War Graves Commission are also in attendance. The board must come to a unanimous decision following the presentation and review of all the data included in the investigation. Should the recommendation be accepted, the burial of the remains in the closest appropriate cemetery to where the soldier fell is the next and final step.



Cemetery at Pheasant Wood, Fromelles honoring Australian soldiers who died in the First World War.

mcnovies/Alamy Stock Photo



Hemis/Alamy Stock Photo

France, Indre, Saint Marcel, archaeological excavation (aerial view).

The Casualty Identification Program is also able to respond should a potential mass grave of Canadian soldiers be discovered; similar to the joint British¹¹ and Australian¹² excavation project at Fromelles in France, which resulted in the discovery of 250 Australian soldiers who died in 1916 and were buried by the Germans in eight mass graves.¹³ Should such a situation become reality for Canada, it is vital that the project be approached from a forensic archaeological and anthropological perspective to optimize the proper recovery of the remains.¹⁴ Any such excavation needs to be carefully planned so that the identification process is not hindered by something easily anticipated by a forensic anthropologist or archaeologist. No amount of preparation can concretely determine exactly what will be found within a mass grave. Several archaeological surveying techniques, such as ground penetrating radar and digging test pits, amongst others, can inform the scope of the excavation but it will not show how many bodies are within or how they are laid out. Commingling (i.e., the bodies/bones are mixed) will likely be a factor that needs to be addressed. Proper forensic archaeological excavation reduces the magnitude of commingling due to its systematic excavation process where bodies are fully revealed (as much as possible) prior to removal. Furthermore, the location of artefacts, such as an

“The Casualty Identification Program is also able to respond should a potential mass grave of Canadian soldiers be discovered.”

identification disc found near the shoulder or the hip, can greatly inform whether it belonged to the individual with whom it was contextually associated. If an artefact is removed from the grave without proper recording of its context, it essentially becomes unusable for identification purposes because we cannot be sure where it was found.¹⁵ Yes, archaeological excavations can be lengthy and costly in certain instances; however, to ensure the dignity of the dead as well as optimize the likelihood of identification, proper archaeological methods and procedures are essential.¹⁶

Since the formal inception of the Casualty Identification Program (and at the time of publishing), 32 sets of remains have been positively identified and subsequently buried with their name. Unfortunately, five sets of remains have been buried as Unknown or Unknown Canadian soldiers as the investigation into their identity had reached its, hopefully temporary, end for a variety of reasons. However, we do ensure that all biological data, including generating DNA profiles, is collected prior to burial as an Unknown Soldier so that the investigation can continue should new evidence become available. There are currently 41 sets of remains under investigation with the Casualty Identification Program.



Tractors excavate the scene of the Ethiopian Airlines Flight ET 302 plane crash, near the town of Bishoftu, southeast of Addis Ababa, Ethiopia, 10 March 2019.

I am frequently asked by members of the public, the media, etc. why this work is important. For me, as a forensic anthropologist, it is simple. I do this work so that these individuals have their name and face returned to them. My colleagues who are military members have expressed to me the notion that this work reinforces a sentiment within the Canadian Armed Forces that you will be taken care of. They view it as if the worst were to happen, and their remains could not be immediately recovered, they know that there will be someone working to recover and identify their remains so that they can be properly buried with their name.

To read more about the Casualty Identification Program, go to our website.¹⁷ There you can read biographies of the Canadian soldiers and airmen who have been identified. You can also register with us if you have a relative from the First and Second World Wars, and the Korean conflict with no known grave.¹⁸ You can also review the Defence Administrative Orders and Directive 5040-3, Unaccounted-for Military Fatalities from Past Operations¹⁹ for which the Directorate of History and Heritage is responsible. While the Casualty Identification Program continues to be my main responsibility as Casualty Identification Coordinator, there are other scenarios where the skills and knowledge of a forensic anthropologist could be helpful within the realm of the Canadian Armed Forces' business.

“I am frequently asked by members of the public, the media, etc. why this work is important. For me, as a forensic anthropologist, it is simple. I do this work so that these individuals have their name and face returned to them.”

Disaster Victim Identification

The need for Disaster Victim Identification arises in a variety of scenarios which result in mass fatalities. A few examples include the World Trade Center on 11 September 2001, the tsunami in the Indian Ocean on 26 December 2004, or the more recent Boeing 737 Max 8 Lion Air and Ethiopian Airlines crashes on 29 October 2018 and 10 March 2019, respectively, as well as the 2018 wildfires near Paradise, in northern California. Each of these events resulted in many fatalities where the human body was subjected to extreme forces or environmental factors. The remains at disaster scenes are often fragmented; commingled, sometimes with animal bones; scattered; burned and/or decomposing. These factors will affect the recovery of the remains and the subsequent identification process.

The Canadian Armed Forces has a team dedicated to Disaster Victim Identification, which is the Canadian Forces Forensic Odontology Response Team (CF FORT). CF

FORT was founded in 2010 and is composed of 12 members: eight dental officers and four dental technicians. The CF FORT is responsible to the Dental Corps, which mandate requires capabilities to identify fallen soldiers on the battlefield and has been doing so since the Second World War. CF FORT is ready to deploy at all

times should the need arise and has been called upon in the past by federal, provincial, and territorial governments to assist with Disaster Victim Identification missions, both in Canada, such as the Swiss Air Flight 111 crash in 1998 and the First Air Flight crash 6560 in 2011, and abroad with the earthquake in Haiti in 2010.²⁰ CF FORT also provides valuable assistance to the Casualty Identification Program by undertaking dental analyses of newly discovered remains when teeth are present in the skeletal assemblage and when dental records are available in the soldier's or airman's personnel file. Their previous assistance with the program has exponentially increased the likelihood of identification for the cases where their services and expertise could be included in the investigation.

The Canadian Armed Forces can add to its capabilities in Disaster Victim Identification by also offering the services of a forensic anthropologist. In the past, forensic anthropologists were used to create biological profiles of the victims to aid in identification. Due to advances in other fields and technology such as DNA, a formal identification can be achieved quickly and may not require a biological profile of the remains to aid in that process. In cases of Disaster Victim Identification, a list of the dead and/or missing may be easily

obtained, such as a flight manifest; therefore, immediately requesting samples from family members such as parents or children of the decedents can be a simpler process than tracing living family members of individuals who died more than 100 years ago. There are many other ways that the forensic anthropologist can contribute to situations of Disaster Victim Identification.²¹ I have been trained and am prepared to contribute to such situations by providing knowledge and contributing to almost every phase of the recovery and identification process. For example, during the initial planning phase and recovery phase, I can provide valuable insight into the possible condition of the remains which would inform the scope and planning of the recovery effort.²² I also have archaeological training and experience and can advise on the use of proper archaeological protocols for the recovery which assures the remains are associated with vital, documented contextual information. During the recovery, I can recognize and segregate any animal bones that may have been recovered, therefore removing them prior to the analysis process. Once the remains have been transferred to the mortuary, I can once again provide insights and knowledge to aid in the process such as assisting in further triage of the remains, sorting any commingled remains and re-associate them, as well as collecting any antemortem

“The Canadian Forces Forensic Odontology Response Team (CF FORT) is ready to deploy at all times should the need arise and has been called upon in the past by federal, provincial, and territorial governments to assist with Disaster Victim Identification missions, both in Canada and abroad.”



DND photo by MCpl Paul MacGregor

Major Steve Hewitt, Company Commander with the Canadian Forces Disaster Assistance Response Team (DART), discusses possible logistical problems with fellow team members Captain Suzan Seo, and Captain Lena Cormier.

(before death) and postmortem (after death) information that could lead to an identification.²³ Finally, I can also be useful in the final phase of the identification process by reviewing the data and ensuring there were no mistakes possibly leading to a false identification.²⁴ There is an extensive amount of literature available that goes into much more detail but ultimately, having an anthropologist, such as myself, as a part of a Disaster Victim Identification team is an asset²⁵ and should be considered at every opportunity where such services are offered by the Canadian Armed Forces. The inclusion of anthropological expertise would complement the Canadian Armed Forces' current in-house capabilities of rendering multidisciplinary services for such a scenario.

Mass Fatality Response Plan

The global COVID-19 pandemic of 2020 has shown us that preparation for the worst-case scenario is an asset. The mass fatalities in some jurisdictions as the result of COVID-19 quickly overwhelmed the system where perhaps unusual methods were used to handle and bury the bodies. The military was called in to assist with the bodies in Italy; military trucks transported the bodies to cremation sites as the morgues were overwhelmed.²⁶ Refrigerated container trucks were used to store the bodies prior to burial. Mass graves were opened in several countries to bury the bodies of those unclaimed by their loved ones²⁷ while some had to forgo traditional religious and cultural burial practices.²⁸

Mass Fatality Incidents are not planned occurrences; nonetheless, we can be prepared to respond to any such event by having a Mass Fatality Response Plan. Evidently, the various jurisdictions and medical examiners' or coroners' offices across the country would be leading such an operation within their own jurisdictions. The Canadian Armed Forces can certainly help the various jurisdictions within Canada and is already doing so in partnership with the Royal Canadian Mounted Police through a Memorandum of Understanding that encourages the mutual sharing of personnel, equipment, and resources when the need arises, such as for Disaster Victim Identification.²⁹ The Canadian Armed Forces is also a partner in the Disaster Assistance Response Team (DART) Organization which is deployed upon request to offer assistance

in other countries that have experienced a natural disaster or other emergency.³⁰ Adding a forensic anthropologist to the list adds another resource that could be offered by the Canadian Armed Forces should the recovery and identification of remains be required. Furthermore, including an anthropological perspective in the discussion of how to respond is beneficial so that the human aspect of the disaster remains an important part of the discussion especially when in cultural and religious environments with traditions and customs that can vary from those in the West.

Over the course of the COVID-19 pandemic, dignity of the deceased has been a topic of discussion and something that must

“Mass Fatality Incidents are not planned occurrences; nonetheless, we can be prepared to respond to any such event by having a Mass Fatality Response Plan.”

DND photo by Major Geneviève Poitras



Group photo of the Canadian Forces Forensic Odontology Response Team taken in October 2019 at the Canadian Police College in Ottawa during annual collective training.

be of the highest consideration when developing the plans and processes to properly deal with the bodies. The International Committee of the Red Cross provides valuable information and guidelines related to the handling of the dead to ensure that it is done with respect and dignity.³¹ Having an anthropologist as a part of this planning process would be greatly beneficial to provide insight into more anthropological and cultural considerations that should be included in a Mass Fatality Response Plan.

Conclusion

I hope that the information above has provided answers to the question of why a forensic anthropologist is part of the Defence Team. While my skillset and knowledge are very pointed and deal with one of the more unpleasant aspects of life (i.e., death), my anthropological background and years of study at the graduate and post-graduate levels can very much be of use outside my responsibilities as Casualty Identification Coordinator. The Casualty Identification Program and its mandate are and continue to be my main responsibility. I hope I have provided a better understanding of my work in

this area as well as the knowledge and skills that a forensic anthropologist can contribute when dealing with the realities of death, especially in unforeseen events such as Mass Fatality Incidents requiring Disaster Victim Identification. Ultimately, when dealing with death, ensuring that the decedents and their families are treated with dignity and respect are of the utmost importance and is the reason why this type of work and associated knowledge is needed.

Acknowledgments

I would like to thank Lieutenant-Colonel Luc Langevin, Major Mélanie Dumas, and Major Geneviève Poitras for providing the information and photographs about the Canadian Forces Forensic Odontology Response Team and for their comments, revisions, and support. Many thanks go to Dr. Catherine Paterson and Dr. Ken Reynolds for their comments, revisions, and support.



NOTES

- National Defence, "Directorate of History and Heritage," <https://www.canada.ca/en/department-national-defence/services/military-history/history-heritage.html>.
- National Defence, "Military Personnel Command," <https://www.canada.ca/en/department-national-defence/corporate/organizational-structure/military-personnel-command.html>.
- Angi Christensen, Nicholas Passalacqua, and Eric Bartelink, *Forensic Anthropology. Current Methods and Practice.*, 2nd ed. (Academic Press, 2019), <https://www.elsevier.com/books/forensic-anthropology/christensen/978-0-12-815734-3>.
- Christopher W. Rainwater et al., "Forensic Anthropology at the New York City Office of Chief Medical Examiner," in *A Companion to Forensic Anthropology* (John Wiley & Sons, Ltd., 2012), pp. 549–66, <https://doi.org/10.1002/9781118255377.ch27>.
- Angela Soler and Jared S. Beatrice, "Expanding the Role of Forensic Anthropology in a Humanitarian Crisis: An Example from the USA-Mexico Border," in *Sociopolitics of Migrant Death and Repatriation: Perspectives from Forensic Science*, ed. Krista E. Latham and Alyson J. O'Daniel, Bioarchaeology and Social Theory (Springer International Publishing, 2018), pp. 115–28, https://doi.org/10.1007/978-3-319-61866-1_9.
- International Commission on Missing Persons, <https://www.icmp.int/>.
- United Nations International Criminal Tribunal for Rwanda, <https://www.ictj.org/>.
- "International Criminal Tribunal for the Former Yugoslavia | United Nations International Criminal Tribunal for the Former Yugoslavia," <https://www.icty.org/>.
- National Defence, "Casualty Identification Program," <https://www.canada.ca/en/department-national-defence/services/military-history/history-heritage/casualty-identification-military.html>.
- "Commonwealth War Graves Commission," <https://www.cwgc.org/>.
- MOD War Detectives – the Joint Casualty and Compassionate Centre, <https://www.gov.uk/guidance/mod-war-detectives-the-joint-casualty-and-compassionate-centre-commemorations-team-what-we-do>.
- Unrecovered War Casualties-Army, "World War One - The War to End All Wars | Army.Gov.Au," <https://www.army.gov.au/our-work/unrecovered-war-casualties/world-war-one-war-end-all-wars>.
- Louise Loe et al., "Remember Me to All": The Archaeological Recovery and Identification of Soldiers Who Fought and Died in the Battle of Fromelles, 1916 (Oxford Archaeology, 2014).
- Margaret Cox, Ambika Flavel, and Ian Hanson, *The Scientific Investigation of Mass Graves: Towards Protocols and Standard Operating Procedures* (Cambridge University Press, 2008).
- R. Wright, I. Hanson, and J. Sterenberg, "The Archaeology of Mass Graves," in *Forensic Archaeology: Advances in Theory and Practice* (Routledge, 2005), pp. 137–58.
- Loe et al., "Remember Me to All."
- National Defence, "Casualty Identification Program."
- National Defence, "Register to Find Your Missing Military Family Member," <https://www.canada.ca/en/department-national-defence/services/military-history/history-heritage/casualty-identification-military/register-missing-military-family.html>.
- National Defence, DAOD 5040-3, Unaccounted-for Military Fatalities from Past Operations, <https://www.canada.ca/en/department-national-defence/corporate/policies-standards/defence-administrative-orders-directives/5000-series/5040/5040-3-unaccounted-for-military-fatalities-from-past-operations.html>.
- Email from Major Mélanie Dumas, 14 May 2020.
- Hans H. de Boer et al., "The Role of Forensic Anthropology in Disaster Victim Identification (DVI): Recent Developments and Future Prospects," *Forensic Sciences Research* 4, no. 4 (October 2, 2019): pp. 303–15, <https://doi.org/10.1080/20961790.2018.1480460>.
- Sue Black, "Disaster Anthropology: The 2004 Asian Tsunami," in *Handbook of Forensic Anthropology and Archaeology*, World Archaeology Congress Research Handbooks in Archaeology, 2011, pp. 397–406.
- Paul S. Sledzik, "Forensic Anthropology in Disaster Response," in *Handbook of Forensic Anthropology and Archaeology*, World Archaeology Congress Research Handbooks in Archaeology, 2011, pp. 374–87.
- Christopher A. Briggs and Alanah M. Buck, "The Role of the Anthropologist in Disaster Victim Identification: The Bali Incidents of 2002 and 2004," in *Handbook of Forensic Anthropology and Archaeology*, World Archaeology Congress Research Handbooks in Archaeology, 2011, pp. 407–15.
- Amy Z. Mundorff, "Integrating Forensic Anthropology into Disaster Victim Identification," *Forensic Science, Medicine, and Pathology* 8, no. 2 (June 2012): pp. 131–39, <https://doi.org/10.1007/s12024-011-9275-0>.
- Aylin Woodward and Dave Mosher, "Sobering Photos Reveal How Countries Are Dealing with the Dead Left by the Coronavirus Pandemic," *Business Insider*, <https://www.businessinsider.com/coronavirus-covid-19-victims-bodies-burials-morgues-cemeteries-photos-2020-4>.
- Claudia Lauer, and Jessica Gresko, "'It's Heart-Wrenching': Morgues Struggle with Demand as COVID-19 Cases Surge," *Global News*, <https://globalnews.ca/news/6778532/coronavirus-morgues-bodies-deaths/>.
- Lauren Frayer, Daniel Estrin, and Jane Arraf, "Coronavirus Is Changing the Rituals Of Death For Many Religions," NPR.org, <https://www.npr.org/sections/goatsandsoda/2020/04/07/828317535/coronavirus-is-changing-the-rituals-of-death-for-many-religions>.
- Telephone call with Major Geneviève Poitras, 1 June 2020.
- National Defence, "Disaster Assistance Response Team (DART)," <https://www.canada.ca/en/department-national-defence/services/operations/military-operations/types/dart.html>.
- "Management of Dead Bodies after Disasters: A Field Manual for First Responders," Publication, International Committee of the Red Cross, 1 December 2015, <https://www.icrc.org/en/publication/0880-management-dead-bodies-after-disasters-field-manual-first-responders>.



Northern Lights shimmer above HMCS *Glace Bay* during Operation NANOOK, 18 August 2020.

Civil-Military Operational Support to the “Heart of Canada’s North”: Looking to Alaska and the Australian North for Options?

by Peter Kikkert and P. Whitney Lackenbauer

Dr. Peter Kikkert is the *Irving Shipbuilding Chair in Arctic Policy* in the *Brian Mulroney Institute of Government* at *St. Francis Xavier University*.

Dr. P. Whitney Lackenbauer is the *Tier 1 Canada Research Chair in the Study of the Canadian North* at *Trent University* and *Honorary Lieutenant-Colonel of 1st Canadian Ranger Patrol Group*.

Strong, *Secure, Engaged* (2017) and the Government of Canada’s Arctic and Northern Policy Framework (ANPF; September 2019) highlight the importance of relationship building and engagement between the Canadian Armed Forces (CAF) and northern Indigenous Peoples as the military leverages its new capabilities to “support broader Government of Canada priorities.”¹ Over the last decade, the CAF has strengthened community engagement during routine operations, exercises, and annual deployments to and in the North, and its ongoing relation-

ships with communities through the Canadian Rangers and the Junior Canadian Ranger program that provide vital connections with local stakeholders and rightsholders.² In committing the Defence team to enhance its Arctic capabilities, *Strong, Secure, Engaged* explains that the CAF will continue to “work to expand and deepen our extensive relationships with these communities.” This also invites new ways to “work with territorial governments and Indigenous communities to ensure [that] the North achieves its full potential both in terms of resource development and community capacity building.”³

The CAF’s public description of Operation NANOOK places particular emphasis on its relationships with the “Indigenous communities” that form “the heart of Canada’s North,” which it works to strengthen “through collaborative and continuous discourse throughout the year.”⁴ Since its first iteration in 2007, this operation has allowed the CAF to strengthen its northern capabilities while addressing security and safety challenges that accompany climate change and increased human activity in the

region. Bolstering cooperation between the CAF, other federal agencies and departments, territorial, municipal, and Indigenous governments, Inuit associations and regional corporations, and northern communities more generally has solidified relationships and mutual understanding, enhanced interoperability and readiness, and reaffirmed why a CAF presence brings positive benefits in and for Northern communities. Rebranded in 2018 as a year-round initiative, NANOOK now encompasses various deployments including NUNALIVUT, NANUKPUT, TATIGIIT, and TUUGALIK.⁵

To strengthen its “continuous and collaborative discourse” with Northerners and support the federal government’s ANPF objectives, the CAF might look for new models and approaches in the remote northern regions of two close allies: the United States and Australia. The Innovative Readiness Training (IRT) exercises carried out by the U.S. Department of Defense (DoD) in Alaska and the long-standing Australian Army Aboriginal Community Assistance Program (AACAP) offer examples of how the CAF might consider broadening its engagement with remote northern Indigenous

“Bolstering cooperation between the CAF, other federal agencies and departments, territorial, municipal, and Indigenous governments, Inuit associations and regional corporations, and northern communities more generally has solidified relationships and mutual understanding, enhanced interoperability and readiness, and reaffirmed why a CAF presence brings positive benefits in and for Northern communities.”

communities. These relatively small but mutually beneficial deployments directly contribute to community health, well-being, and resilience, while providing training experiences to a wide cross-section of military personnel.

**“This Absolutely Prepares Them for a Deployment”:
Innovative Readiness Training Missions in Alaska**

DoD’s IRT initiatives aim to “produce mission-ready forces through military training opportunities that provide key services to underserved communities throughout the U.S.”⁶ Specific objectives include the provision of “hands-on, real-world training to improve readiness and survivability in contingency environments,” the cultivation of civil-military partnerships with a “culturally complex population,” and the development of innovative resource management by leveraging “military contributions and community resources to multiply value and cost savings for participants.”⁷ Projects begin with applications from federal, state, local, or tribal governments, non-profit entities, or community organizations asking for military assistance for

DND photo by Corporal Pierre Létourneau/CX2013-A002-01



Ranger, Corporal Paul Ikuqllaq packs his komatik before leaving on a two-week patrol from Resolute Bay during Operation NUNALIVUT, 10 April 2013. A komatik is a traditional sled for carrying cargo in the North.



Platoon 1 of the Arctic Response Company Group (ARCG) and the Canadian Rangers travel to pick up Platoons 2 and 3 to move to the next position during Exercise GUERRIER NORDIQUE in Iqaluit, Nunavut, 4 March 2014.

projects and laying out what local support, funding, resources, and partners they can contribute. Applications must also certify that the military’s assistance is not “reasonably available” from a commercial entity or that the private sector “has agreed to the provision of such services by the Armed Forces.”⁸ Under the guidance of the Director, Civil-Military Training Policy, in the Office of the Deputy Assistant Secretary of Defense for Reserve Integration, military services then choose projects based on current training needs and value.⁹ The military assistance provided under the IRT program generally includes healthcare delivery, infrastructure support (including runways, roads, bridges, buildings, and marine installations), cybersecurity, youth training programs, and veterinary services.

IRT missions in Alaska provide soldiers with key training opportunities and experience in civil-military relations, joint service interoperability, engineering and construction skill building, healthcare delivery, logistics, and transport. Personnel receive extensive, “real-world” training on the

equipment they will use and practices that they will employ when deployed on operations abroad.¹⁰ Reports about Alaskan IRT missions often highlight their role in boosting morale and encouraging personnel retention. These projects also provide the chance to work with international partners, including CAF members and other Canadian health professionals.¹¹ In short, these experiences improve deployment readiness: the ultimate objective of the IRT program.

“In executing IRT projects for communities that lack the resources to carry them out on their own, military units are given the chance to practice essential skills, including the organization and execution of complex engineering and construction tasks, the establishment of effective health services in new and challenging environments, and the provision of logistical, transportation, and communications support.”

In executing IRT projects for communities that lack the resources to carry them out on their own, military units are given the chance to practice essential skills, including the organization and execution of complex engineering and construction tasks, the establishment of effective health services in new and challenging environments, and the provision of logistical, transportation, and communications support.¹² The majority of these projects also involve a high degree of joint service cooperation, allowing units to practice their interoperability in a wide variety of settings, often for

extended periods.¹³ IRT initiatives usually demand a high degree of interagency, intergovernmental, and community coordination, and occasionally include multi-national partners, providing service members with experience “integrat[ing] as a joint and whole-of-society team to serve American citizens.”¹⁴ DoD highlights that these projects are designed to increase deployment readiness and foster civil-military relations, while “enhancing morale and contributing to military recruitment and retention.”¹⁵ During times when budget constraints cut into military training opportunities, IRT is a “win-win” practice that provides the military with skill-building experience and communities with essential services.¹⁶

Conducted on an annual basis since 1995, Operation ARCTIC CARE is the longest running IRT initiative in Alaska and has become one of the largest recurring joint military medical and logistics training exercises in the United States.¹⁷ The operation is designed to provide service members with experience deploying a range of medical capabilities to remote and underserved communities in an austere northern environment, while providing required care to Alaskans who might not receive it otherwise or would have to travel long distances to acquire it.¹⁸ ARCTIC CARE generally involves the two-week deployment of between 100 and 300 service personnel from the Reserve, National Guard, and active components of the Army, Navy, Air Force, Marine Corps, and Coast Guard, to multiple Alaskan villages. Each year, the initiative rotates to a different region, including the Northwest Arctic Borough, Kodiak Island Borough, Yukon-Kuskokwim Delta, and Little Diomed Island. Service personnel offer a “blitz of services”

in these communities, including medical, dental, and optometry care, on-site production of eyeglass prescriptions, pharmacy access, physical therapy, educational courses in CPR, first aid, nutrition, and other health related topics, and veterinarian check-ups, spaying, and neutering.¹⁹ In ARCTIC CARE 2018, for instance, 140 practitioners deployed to 12 villages in the Maniilaq Service Area of the Northwest Arctic Borough between 13 and 27 April, where they treated more than 2,000 patients and, notably, offered cancer screenings and a surgery clinic to perform colonoscopies.²⁰ These deployments are dependent on relationship-building and are rooted in partnerships with an array of Native corporations and associations, the Alaska Native Tribal Health Consortium, the Alaska Area Native Health Services, state and local governments, and the communities.

Other IRT projects have focused on community-level infrastructure development. Since 2009, several initiatives have supported the relocation of the Yupik village of Newtok nine miles upriver to escape coastal erosion and flooding. The military’s involvement began with the establishment of a footprint at the relocation site at Mertarvik, including a 13,272-square foot billeting pad using Dura-base matting. In 2010, the project involved the construction of a forward operating base and a 1,500-foot access road, providing a link to the barge landing site, from which the bulk of construction supplies would flow. The next three years saw the construction of underground utilities for the community evacuation centre, storage buildings, the establishment of a rock quarry, and other preparatory work that paved the way for the arrival of



US Air National Guard photo by Master Sgt. Carl Clegg

Chief Master Sergeant Tori Hill, 108 Medical Group, Arctic Case NCOIC, left, Major Jean Chevalier, 41 CF Health Services Centre, Canadian Armed Forces, center, and Major Lisa Haik, 919th Special Operations Medical Squadron, Arctic Care AOIC coordinate the movement of both troops and supplies for the Exercise ARCTIC CARE at the Army Reserve 99th Regional Support Command’s Equipment Concentration Site 99 warehouse on Joint Base McGuire-Dix-Lakehurst, NJ, 25 February 2016.

civilian contractors.²¹ In summer 2019, the IRT program re-engaged with the relocation effort, with military personnel deploying to Mertarvik to build roads, a landfill site, heavy equipment shop, and 13 homes, which allowed for the first wave of residents to move into the new village.²² Since 2012, another multi-year IRT mission has been focused on the small community of Old Harbor on Kodiak. The remote village is highly dependent on the fishing industry and desired expansion of its operation by constructing a new cannery and hydroelectric plant.²³ Between 2012 and 2018, the program also successfully completed a 2,000-foot runway extension requested by the community and has initiated work on the construction of a one-mile access road to the site for the proposed Old Harbor Hydroelectric Powerhouse and new fish hatchery facility.²⁴

Operation ALASKAN ROAD is indicative of the challenges and benefits associated with these joint task force projects. From 1997–2007, this operation involved the construction of a 14-mile road to connect the fly-in community of Metlakatla to a planned ferry terminal on Alaska’s Inside Passage, which would provide access to Ketchikan (the state’s fifth most populous city). The federal government had first promised to build such a road six decades earlier, and community members insisted it would improve the medical, educational, and commercial opportunities available to the community.²⁵ Construction had to manage challenging geographical conditions, including dense muskeg (sometimes 25 feet deep), mountainous terrain (the project demanded blasting and moving 1.5 million cubic yards of rock), and heavy annual

rainfall.²⁶ While these factors complicated the project, they also enhanced its training value – particularly the rock, given that military engineers usually work primarily with dirt.²⁷ To support the project, the military established Base Camp Wy Wuh, including administrative offices, barracks, warehouses, tool rooms, a water treatment plant, and wastewater treatment plant.²⁸ Every construction season approximately 12,000 personnel from units across the US, serving on two- to three-week rotations, slowly extended the road, overcoming environmental challenges, equipment malfunctions, and exhausting work days. The inclement weather, short construction season, design modifications, and the training needs of deployed personnel stretched the project over a decade,²⁹ but a completed road was handed over to the community in August 2007.

Alaskan IRT initiatives offer up challenges and opportunities different than those encountered in the lower 48 states, providing service personnel with experience operating in austere and often harsh northern environments. One reporter who interviewed personnel working on Operation ALASKAN ROAD noted:

A visitor looks at this rocky, chilly, mountainous, densely forested terrain and thinks: Alaska, America’s last frontier. The Marine Corps looks at the same rugged landscape and thinks: the Korean Peninsula, a potential international hot spot. For the Marine Corps, Operation ALASKAN ROAD is a priceless opportunity to get realistic training in building a combat-ready road through



US Air Force Photo by 1st Lt. Rashard Coakum

US service members load an Alaska Army National Guard UH-60 Black Hawk with cargo at the Ralph Wien Memorial Airport, in Kotzebue, Alaska, in support of Exercise ARCTIC CARE, 14 April 2018. Military personnel accomplished critical mission training to maintain currency needed to support future contingency and humanitarian operations.



© Commonwealth of Australia/S20171589

Chief of Army, Lieutenant General Angus Campbell (centre), AO, DSC, and Warrant Officer Don Spinks (left), OAM, Regimental Sergeant Major of the Australian Army, receive a brief during a visit to meet soldiers of the Army Aboriginal Community Assistance Programme in Toomeleh, New South Wales.

one of the most hostile, forbidding natural environments on Earth, such as the one they might face in Korea.³⁰

The rugged environmental conditions, weather-related challenges, lack of infrastructure, and remoteness demand greater attention to planning and organization, require heightened operational adaptability, and test leadership.³¹ In particular, operating in remote Alaskan villages provides an array of unique logistical and transportation challenges. If something goes wrong or equipment breaks, service personnel have to problem solve and self-generate on the spot because assistance and resupply is usually hundreds of miles away.³² The IRT team at Mertarvik, for instance, was 600 miles from the closest supplies, challenging them to use or re-purpose all of their materials wherever possible.³³ These deployments also offer significant opportunities for cross-cultural engagement, with personnel living full time in Indigenous communities and participating in community life.³⁴

“The rugged environmental conditions, weather-related challenges, lack of infrastructure, and remoteness demand greater attention to planning and organization, require heightened operational adaptability, and test leadership.”

Consequently, participants highlighted the value of these missions to them for deployments into challenging operating environments around the world. Those on Operation ARCTIC CARE stress its value for simulating military-civilian humanitarian operations and healthcare delivery in times of crisis, conflict, or disaster.³⁵ Alaska Army National Guard brigade engineer operations sergeant Seth Gordon, who deployed on the Old Harbor IRT mission spanning three seasons, echoed this: “It’s a win-win situation; we get to travel to a remote location, operate out of a small camp much like a forward operating base and get training on equipment that is needed to complete this project.”³⁶ Electrician Chief Sgt. Philip Ankney with two deployments to Afghanistan, noted its similarity to “living on a FOB, being in the field and just working. My Marines that haven’t deployed were exposed to a different culture and a different way of living. This absolutely prepares them for a deployment when they get the opportunity.”³⁷



© Commonwealth of Australia/S20191836

The AACAP Construction Troop from the 21st Construction Squadron work with civilian equipment to mix high volumes of concrete necessary for culvert bases.

Through these activities, Alaskan communities benefit from access to healthcare, new infrastructure, and enhanced relationships with the US military. Cynthia Berns, the vice president of community and external affairs with Old Harbor Native Corporation, explained how her community “built a wonderful friendship with so many service members that have come to help in our community. We will forever be thankful to the Marine Corps for coming to our village. They have truly made a lasting impact.”³⁸ Such accolades might serve to inspire Canadian officials, given the desire for CAF operations and training to have positive, “enduring effects” on socio-economic life in northern communities.³⁹

**“A Great Vehicle for Us to Support the Nation”:
Australia’s Army Aboriginal Community
Assistance Program**

The Australian Army combines multiple IRT type initiatives into a more comprehensive approach through its Army Aboriginal Community Assistance Program (also called Exercise SAUNDERS in recognition of Reg Saunders, the first Indigenous Australian to be commissioned as an officer in the Australian Army).⁴⁰ In 1996, Prime Minister John Howard

and the ministers for Aboriginal and Torres Strait Islanders Affairs, Defence, and Health and Family Services launched the Aboriginal and Torres Strait Islander Commission Army Community Assistance Program to address concerns about Indigenous health and well-being raised by the Council for Aboriginal Reconciliation.⁴¹ The government provided the Army with \$11.7 million in program funding between 1997–2000 to provide housing and other infrastructure improvements in eight communities across the Northern Territory, Western Australia, Queensland, and South Australia.⁴²

This successful program was subsequently extended (although re-scaled owing to over-stretched Army engineering assets). Lt. Colonel Noel Beutel, who was responsible for the AACAP missions in 2006–2007, explained that the program tapped into “Army’s ability to holistically deliver a range of services not normally available in any single project, and thereby maximise the benefits provided to a community.”⁴³ While AACAP had started with up to four deployments to multiple communities each year, after 2008 it focused on one (or two if they were geographically close) with an annual budget of \$6 million.⁴⁴ Currently the program provides \$7 million each fiscal year through the Indigenous

Advancement Strategy (IAS) of the Department of the Prime Minister and Cabinet (PM&C) Indigenous Affairs Group, with the Army providing similar value of in-kind support to the program.⁴⁵

AACAP allows the Australian Army to fulfill several key objectives. A 2017 evaluation highlighted the immense training value it brings to Army. “The delivery of an AACAP project requires the generation, preparation, deployment and sustainment of a military contingent to remote locations in Australia for extended durations,” it noted, “and exercises the full range of the Defence supporting capabilities required. Through AACAP, Army aims to train and test selected capabilities against the themes of ‘population support’ and ‘Indigenous capacity building.’”⁴⁶ By focusing on community engagement and capacity building, AACAP also supports the Army’s Indigenous Strategy, which commits to a whole of government approach to building relationships and “contribut[ing] to the development of Indigenous communities.”⁴⁷ Likewise, the program has become a key pillar of the Australian Defence Force’s Defence Reconciliation Action Plan, which calls for “building respectful relations with Indigenous people, communities and organisations” and “the development of a consistent Defence approach to building relationships” with these communities.⁴⁸ AACAP also represents a military contribution to the Australian government’s Closing the Gap initiative aimed at improving Indigenous life expectancy and overall health, education, and employment outcomes.⁴⁹ Contingent commander Major Henry Stimson highlighted this latter role when he explained that “from Army’s perspective AACAP is a mechanism for our own training benefit, but also it’s a great vehicle for us to support the nation by assisting in the ongoing development in these remote communities.”⁵⁰

While the first AACAP initiatives were primarily directed towards infrastructure support, each mission now involves three key components: construction, health, and training.⁵¹ The construction component focuses on “critical infrastructure to improve the wellbeing of marginalized communities” including airfields, improved roads and causeways, health clinics and administration buildings, water and waste treatment plants, housing and subdivisions, education facilities, childcare facilities, telecommunications, and projects that directly support economic growth.⁵² Under the health component, personnel deploy to the communities to provide medical, dental, and veterinary services, accredited and non-accredited health training (e.g., first aid, nutrition), and physical training and education programs.⁵³ Finally, the training component provides structured programming for “community members in a range of areas (e.g., construction, welding, small engine maintenance, hospitality, business skills) to enhance job readiness and employment opportunities.” A training development officer assigned to each mission works with the community to determine what kind of training and educational experiences to

“AACAP also represents a military contribution to the Australian government’s Closing the Gap initiative aimed at improving Indigenous life expectancy and overall health, education, and employment outcomes.”

provide. When possible, service members also take on “tasks of opportunity” that deliver additional benefits beyond the planned project components, including minor construction and repair work using “residual capacity” that does “not incur an ongoing maintenance liability” (such as improving football fields and other recreational facilities). Finally, each AACAP mission involves an array of community engagement activities including sports and recreation, youth engagement, entertainment, and cultural events.⁵⁴

A typical AACAP mission runs for three years. The process to choose a community site begins roughly 24 months before deployment to ensure sufficient time to secure resources and undertake extensive community engagement and relationship building through the project feasibility, planning, and design stages. Missions begin with a list of potential communities provided by the PM&C in consultation with state and territorial governments, followed by Feasibility Reconnaissance Visits to examine community suitability and needs. For communities to make it onto the short list, they must meet the following basic criteria:

- be remote;
- require works that align with [the Council of Australian Governments’] Closing the Gap initiative;
- provide a sufficient training opportunity for Army;
- be supportive of AACAP;
- have suitable land-tenure arrangements for identified capital works;
- have limited policies and programs that overlap with AACAP;
- have not received AACAP previously.⁵⁵

Sites are chosen based on community need and the training value of the proposed mission. The Minister of Indigenous Affairs makes the final decision after extensive consultation with key government stakeholders and with the community itself.⁵⁶ Once a community is selected, the Army undertakes scoping reconnaissance to verify initial observations and ideas and then develops a preliminary program of work with the community. Objectives are set only after extensive “culturally sensitive consultation” and community approval. During the development stage, the Army, PM&C staff, community members, and other stakeholders devise a detailed “scope of works package” that incorporates all three main program components. Finally, in the delivery stage of the program, between 150–200 personnel deploy for three to six months, with a further 150–300 cycling through on shorter rotations. Following completion of an AACAP mission, engagement continues with at least two more community visits in a 12-month period to ensure that all built elements are still functioning properly.⁵⁷

Over the last two decades, AACAP has improved at integrating missions with other governmental programs, ensuring that Army's efforts support the priorities of state, territorial, and local governments. "When we deploy we try to coordinate with any existing programmes that are going on in a particular community, it's not a set template so we have to treat each community on a case by case basis," Army Force Engineer Colonel Steve Gliddon explained in December 2014. "One of the things that we do look at when we plan is what else is going on, who else is operating there and what other programmes are being rolled out, so we capitalise on existing efficiencies and synergies." The Army also looks for long term program partners that will take over ownership and maintenance responsibilities for whatever they build.⁵⁸ Lt. Colonel Beutel captured the complexity of each deployment, explaining that:

They involve a nexus of stakeholders, enablers, relationships, methods of interaction and at times, all with very different values, norms and practices. In order to understand and then align this complex environment towards the achievement of project goals, a 'project delivery model' has been developed that maps the various stakeholders and enablers and then, through a combination of Memorandums of Understanding, shared responsibility

agreements, operation orders, and commercial agreements and contracts, establishes the subsequent roles and responsibilities, lines of communication and methods of interaction required for project delivery. This is not a simple task, particularly given the gap (or some may say chasm) that must be overcome in bringing the various elements of Army, the three levels of government, civilian consultants and contractors, and the community itself to a mutual understanding, agreement and collaboration in what can be achieved and how best to achieve it.⁵⁹

While building relationships and working with a complex group of stakeholders can be difficult and time-consuming, frequent interactions both improve project outcomes and increases the training value for the Army.

"With engineers, training team, logistics support and various health elements," one report highlighted, "the Army is able to deliver a unique range of services not normally delivered by a single organisation."⁶⁰ On a typical AACAP deployment, 70 percent of the force is made up of engineers, while 30 percent consists of support (e.g., signals, logistics, and training) and medical personnel. Construction components are spearheaded by the 19th Chief Engineer Works, which includes engineering officers, engineering



© Commonwealth of Australia/S20151897

Australian Army soldiers (left to right) Major Chris Sampson, Contingent Commander, Colonel Steve Gliddon, Force Engineer 6th Brigade Headquarters, and Sergeant Gavin Williams, site foreman, take Senator the Hon. Nigel Scullion, Minister for Indigenous Affairs, on an inspection of the construction of the waste treatment system at Titjikala, Northern Territory, as part of the Army Aboriginal Community Assistance Programme 2015.



© Commonwealth of Australia/S20191961

Lance Corporal Nathan Freylinger of the 10th Force Support Battalion at Amberley Qld was the lead hospitality trainer for AACAP 2019.

supervisors, draftsmen, and surveyors experienced in design and project management. Most of the personnel who deploy to the communities for construction are from the 6th Engineer Support Regiment, often supplemented by other Royal Australian Engineers and tradespeople from the Air Force and Navy. Medical personnel are drawn from the Royal Australian Army Medical Corps (which includes veterinary services) and the Royal Australian Army Dental Corps. Reservists, including construction engineers and medical personnel, also deploy on AACAP missions in two- to three-week stints. Whenever possible, AACAP missions also include local Indigenous personnel from the Army's Regional Force Surveillance Units (RFSUs), North-West Mobile Force (NORFORCE), and Pilbara Regiment, 51st Battalion, Far North Queensland Regiment. These personnel assist with community engagement and communications, and serve as mentors to community members who participate in the training. On occasion, multinational personnel are brought in from East Timor, Tonga, and Papua New Guinea to interoperate with ADF personnel, as are civilian contractors when required.⁶¹

Since 1997, 45 AACAP projects have been delivered in 43 communities across Australia, for example:

- AACAP 2007 deployed to the Doomadgee in Queensland and provided four 3-bedroom houses, a community amenities block, a 10-block fully serviced subdivision; and a 12-week employability training program in welding for 20 community members.⁶²
- AACAP 2008 deployed to Kalumburu, Western Australia, and demolished an existing health clinic and built a new one, constructed a new barge landing, and upgraded an access road and the community's airfield.
- AACAP 2013 deployed to WHERE and constructed a Children and Family Centre, four new homes, upgraded the community water supply, constructed service providers' accommodations, refurbished the community church, and a training program sought to improve the self-reliance of community members with courses in small engine repair, basic construction, and home repairs.⁶³



Commanding Officer 5th Engineer Regiment Lieutenant Colonel Renée Kidson (centre) updates Emergency ADF National Support Coordinator, Major General Justin “Jake” Ellwood, DSC (left) and Tentara Nasional Indonesia (Indonesian National Armed Forces) Lieutenant Colonel Teddi on the work being conducted by troops at the Zig Zag Railway, Lithgow.

- AACAP 2014 deployed to Canteen Creek and Wutunugurra in the Northern Territory, where service members built a new sealed road to reduce dust and increase accessibility in the wet season, a new workshop and community centre, and a large playground. The training program offered community members a Certificate in Basic Fabrication and Welding and taught them how to manufacture bed frames and furniture for the new houses. Army also brought in multi-media specialists to assist the Barkley Women’s Art Group in developing a business website, complete with catalogue production.⁶⁴
- AACAP 2015 focused on the small town of Titjkala (pop. 200) in the Northern Territory for a four-month deployment that had them building a complex, large-scale waste management system, two duplex houses, and a change room for the football field. The program also offered training in welding and cooking. According to training mentor and army reservist Gary Keegan, “Mines use [our training] as a probation period. They take some of the lads who’ve finished into a trainee program. If you can get one person qualified, you’ve done your job. We learn from them, they learn from us. It’s win-win.”⁶⁵
- AACAP 2018 deployed to the community of Yalata on South Australia’s West Coast, where service members focused on rebuilding the area’s tourism opportunities. The project involved an upgrade to the community’s trailer park, improvements to the airfield, the construction of an art gallery and café, and maintenance and hospitality training for community members who wished to work in

the new facilities.⁶⁶ This program highlights a staple of AACAP training components – providing training that is directly linked to local employability and that the community deems suitable and relevant. As an example of the kind entertainment and outreach events that AACAP missions often employ, this iteration brought in the Indigenous Hip Hop Project (IHHP), a team of performers in hip hop, media, entertainment and the performing arts who work in Indigenous communities throughout Australia.⁶⁷

AACAP is a recognized name in Indigenous communities across Australia for the positive socio-economic and infrastructure contributions made under its auspices.⁶⁸ Indigenous respondents to the 2017 AACAP review highlighted new infrastructure and housing, improved living conditions, clean water, effective sanitation systems, educational opportunities, and the short-term access to round-the-clock healthcare provided by the program. “AACAP in its current form is widely regarded by communities as a successful programme that is very effective in meeting its intended objectives,” the review concluded. “The Programme positively contributes to practical reconciliation between Indigenous and non-Indigenous Australians; with communities reporting an improved understanding of, and enhanced respect for Army; and Army reporting increased understanding and appreciation of Indigenous culture.”⁶⁹

Cultural awareness, relationship building, and stakeholder engagement in each AACAP mission bring broader operational benefits for the Australian Defence Force – and boost the morale

of service members. Lt. Colonel Renée Kidson, currently the CO of 5th Engineer Regiment, argues that:

AACAP is about more than infrastructure. The real value in these projects are the *relationships* we have forged with Indigenous communities along the way. Through mentoring and coaching, part-time Sappers build more than leave-behind infrastructure: they contribute to Indigenous Engagement and Development through trade skills transfer, empowering communities to build brighter futures for themselves. And there is more. AACAP speaks to the heart of one of Army's values: Respect. Sappers return from AACAP culturally enriched, benefiting from deep immersion in Indigenous communities who are generous in sharing knowledge, custom and tradition. These experiences build mutual respect and renewed appreciation of Indigenous communities.⁷⁰

“AACAP also benefits service members by providing opportunities to deploy to isolated areas for extended periods, testing their ability to generate, prepare, and sustain operations and maintain complex lines of communication.”

AACAP experiences have helped the Army prepare for population support activities during past deployments, such as Timor-Leste in 1999 and 2006, and humanitarian assistance and disaster relief operations in Australia and the surrounding region.⁷¹

AACAP also benefits service members by providing opportunities to deploy to isolated areas for extended periods, testing their ability to generate, prepare, and sustain operations and

maintain complex lines of communication. Effective planning and organization are vital. The distances involved and the type of work involved also demand an increased maintenance schedule to prevent equipment breakdowns.⁷² The adaptability and flexibility demanded in these missions make them an appropriate training ground for junior leaders before they deploy overseas.⁷³ Colonel Steve Gliddon, for example, highlighted the value to Army Engineers in Afghanistan:

The sorts of things we're doing in AACAP, building things in remote locations, having to engage with different cultures, is perfect training for operations. If I reflect in particular on Operation SLIPPER where we were in Afghanistan for a number of years building infrastructure in remote locations, engaging with different cultures, dealing with people who are non-English speakers, training Afghans to build their capacity through a trade training school, there are many parallels with AACAP. To go out to a remote Indigenous community and have your junior non-commissioned officers put in charge of a particular task, and then have to complete that task, is perfect training. What we're doing in AACAP directly mirrored what we were doing on operations. One of the reasons that we were able to adapt quickly and perform well in Afghanistan, was the grounding we had given many of our soldiers in things like AACAP.⁷⁴



(From R-L): Officer in Command of 17 Construction Squadron Major Niall Pigott, Doomadgee Mayor Thomas Orcher, Deputy Mayor Elaine Cairns, Housing Officer Shandel Toby and CEO Mal Hansen pose for a photo outside one of the houses constructed through AACAP at the Queensland community.

© Commonwealth of Australia/2007-S1808

Accordingly, units embrace AACAP missions as a useful “training run before we go and do it in real time overseas somewhere,”⁷⁵ with “personnel who have performed well on AACAP [having] a good chance of being able to deploy next year.”⁷⁶

Models of Inspiration for the CAF?

While the geographical and cultural characteristics of the Canadian North give it a “unique nature” as a theatre of operations,⁷⁷ we embrace the benefits that might come from learning from our allies’ experiences in their remote northern regions. The Alaskan IRT initiatives and Australian AACAP projects represent models or approaches that might yield insights for the CAF as it discerns ways to deliver on pledges to enhance its ability to project and sustain forces in the Arctic, deepen partnerships, and improve readiness through activities that leave enduring, positive legacies for Indigenous communities. These operations conducted by our allies fit with priorities articulated in the federal Arctic and Northern Policy Framework, particularly on closing infrastructure gaps and creating conditions so that “Canadian Arctic and northern Indigenous peoples are resilient and healthy.”⁷⁸ At the same time, we acknowledge that these models do raise several challenging considerations in the Canadian context, given budgetary and personnel constraints in the CAF, increasing demands of domestic operations, existing healthcare services (which may leave little space for an ARCTIC CARE type exercise or the AACAP’s health component), and potential encroachments on private industry and civilian employment (although AACAP missions have shown that military construction can actually create new opportunities for civilian contractors, while their training component contributes to Indigenous capacity building and skill development).⁷⁹

The CAF currently performs exercises similar to IRT and AACAP missions in southern Canada – most notably, Exercise NIHILO (Latin for the creation of something out of nothing) SAPPER, an annual training event led by 4 Engineer Support Regiment from 5 Canadian Division Support Base Gagetown that

has completed civilian construction projects in New Brunswick, Cape Breton, and Prince Edward Island in recent years.⁸⁰ The CAF is also developing transportation capacity required to make this kind of civil-military operation easier to accomplish in Northern coastal communities, particularly with the *Harry DeWolf*-class Arctic and Offshore Patrol Vessel.⁸¹ This form of community engagement would also help to operationalize the affiliations that these vessels will be given to various parts of Inuit Nunangat.

Would northern communities welcome an exercise like NIHILO SAPPER – or a broader AACAP-type initiative? While the response would differ from community to community, there

“The Alaskan IRT initiatives and Australian AACAP projects represent models or approaches that might yield insights for the CAF as it discerns ways to deliver on pledges to enhance its ability to project and sustain forces in the Arctic, deepen partnerships, and improve readiness through activities that leave enduring, positive legacies for Indigenous communities.”

are indications that a warm welcome would be received – particularly if the CAF were to adopt the multi-year partnership building approach embraced by AACAP missions. In 2010, Charlie Evalik, the President of the Kitikmeot Inuit Association, described the military as a “cornerstone for Inuit development.” For Inuit, Evalik explained, “an active military presence in the High Arctic is very desirable provided that the strong partnerships that have been forged over specific projects and initiatives can continue into the future.”⁸² Mary Simon’s 2016 *Interim Report on the Shared Arctic Leadership Model* emphasized the

need to close the infrastructure gap in the North, mitigate the damage climate change is doing to existing infrastructure, and address the “public health emergency” caused by the lack of housing.⁸³ CAF support might be welcomed by Northern Indigenous leadership if it helped to alleviate these long-lasting issues as part of its operational training and readiness activities in the Canadian North. While there might be hesitation to a multi-month CAF deployment into a small northern community for fear of overwhelming or over-burdening it,⁸⁴ careful relationship building and an emphasis on practical benefits could alleviate such concerns. Ernest Warrior, a member of NORFORCE who served as a community liaison AACAP 2015, explained that community members were nervous of the large outside influx at first, even after months of preparation, but they quickly grew supportive of the mission when “things started happening.”⁸⁵



DND photo by Corporal David Veldman



The Northern lights can be seen beyond HMCS *Harry DeWolf* during Cold Weather Trials near Frobisher Bay on 21 February 2021.

NOTES

- 1 Department of National Defence (DND), *Strong, Secure, Engaged*, 2017, 80. Crown-Indigenous Relations and Northern Affairs Canada, "Arctic and Northern Policy Framework: Safety, Security, and Defence Chapter," <https://www.rcaanc-cirmac.gc.ca/eng/1562939617400/1562939658000>.
- 2 DND, *Strong, Secure, Engaged*, p. 80.
- 3 Chief of the Defence Staff (CDS), CDS Initiating Directive for the Development of the CAF Arctic Campaign Plan, 21 August 2018, p. 3.
- 4 DND, "Operation Nanook," <https://www.canada.ca/en/department-national-defence/services/operations/military-operations/current-operations/operation-nanook.html>.
- 5 See P. Whitney Lackenbauer and Adam Lajeunesse, "The Emerging Arctic Security Environment," in *Whole of Government through an Arctic Lens*, eds. Heather Nicol and Lackenbauer (Antigonish: Mulroney Institute of Government, 2018), <http://operationalhistories.ca/wp-content/uploads/2018/05/Whole-of-Government-through-an-Arctic-Lens-eBook.pdf>.
- 6 Sgt. Melissa Martens, "Arctic Care 2018 Readiness Training Begins in Northwestern Alaska," *Department of Defense (DoD) News*, 16 April 2018, <https://www.defense.gov/Explore/News/Article/Article/1494560/arctic-care-2018-readiness-training-event-begins-in-northwestern-alaska/>.
- 7 DoD, "Innovative Readiness Training: About," <https://irt.defense.gov/About/>.
- 8 IRT, "Community Application How-To Guide," *DoD*, 27 November 2018, <https://public.huddle.com/b/dvMpMn/index.html>.
- 9 DoD, "Innovative Readiness Training Brochure 2019," https://irt.defense.gov/Portals/57/Documents/IRT_Brochure-20190603%20.pdf?ver=2019-12-17-140228-270.
- 10 Brian Fraley, "Arctic Care 2017 Completed," Kodiak Area Native Association, <http://kodiakhealthcare.org/kana-news/arctic-care-2017-completed/>.
- 11 Defense Visual Information Distribution Service, "Arctic Care 2017," <https://www.dvidshub.net/feature/ArcticCare2017>.
- 12 IRT, "Innovative Readiness Training: Military Value," *DoD* (2020), https://irt.defense.gov/Portals/57/Documents/Senior_DoD_Official_Value_Prop-2020.pdf.
- 13 National Guard, "Innovative Readiness Training Fact Sheet," [https://www.nationalguard.mil/Portals/31/Resources/Fact%20Sheets/Innovative%20Readiness%20Training%20Fact%20Sheet%20\(Dec.%20202017\).pdf](https://www.nationalguard.mil/Portals/31/Resources/Fact%20Sheets/Innovative%20Readiness%20Training%20Fact%20Sheet%20(Dec.%20202017).pdf).
- 14 DoD, "IRT: About."
- 15 Lt. Cmdr. Elizabeth Zimmermann, "Training for Diversity," *The Naval Reservist* 35/9 (October 2009): 6, <https://www.public.navy.mil/nrh/Publications/2009/TNROCT09.pdf>.
- 16 Tony Perry, "Marines Take Long, Hard Road in Alaska," *Los Angeles Times*, 10 August 1998, <https://www.latimes.com/archives/la-xpm-1998-aug-10-mn-11879-story.html>.
- 17 Army National Guard, "OPERATION ARCTIC CARE," <https://www.nationalguard.com/operation-arctic-care>.
- 18 Sgt. Melissa Martens, "Leaving a Warm Touch on the Arctic Circle," *Defense Visual Information Distribution Service*, 25 April 2018, <https://www.dvidshub.net/news/274442/leaving-warm-touch-arctic-circle>.
- 19 Paul Hansen quoted in Gabe Colombo, "U.S. Military Brings Free 'Arctic Care' to Northwest Arctic Communities," *Alaska Public Media*, 19 April 2018, <https://www.alaskapublic.org/2018/04/19/u-s-military-brings-free-arctic-care-to-northwest-arctic-communities/>.
- 20 Shady Oliver, "Arctic Care Brings the Hospital to the Village," *Arctic Sounder*, 12 May 2018, http://www.thearcticsounder.com/article/1819arctic_care_brings_the_hospital_to_the.
- 21 Fenton Reese, "Marine, Sailors, Soldiers, and Airmen Conclude Five-Year, Alaska-Based Operation," *Marine Forces Reserve Headlines*, 6 August 2013, <https://www.marforres.marines.mil/Marine-Reserve-News-Photos/Marine-Reserve-News/Article/521739/marines-sailors-soldiers-and-airmen-conclude-five-year-alaska-based-operation/>.
- 22 Deborah McDermott, "NH Guardsmen Help Alaskan Village Displaced by Rising Sea," 13 October 2019, <https://www.fosters.com/news/20191013/nh-guardsmen-help-alaskan-village-displaced-by-rising-sea>.

- 23 Kayla Desroches, "Old Harbour Infrastructure Project Reaching Fifth Year in Federal Program," *KMXT Radio*, 12 June 2017, <http://kmxt.org/2017/06/old-harbor-infrastructure-project-reaches-fifth-year-federal-program/>.
- 24 Lance Cpl. Tessa D. Watts, "IRT Old Harbor's Runway Extension Completed after Six Years," *Marine Forces Reserve Headlines*, 13 August 2018, <https://www.marforres.marines.mil/Marine-Reserve-News-Photos/Marine-Reserve-News/Article/1600654/irt-old-harbors-runway-extension-completed-after-six-years/>.
- 25 "Operation Alaskan Road Wraps Up 2005 Season," *Stories in the News, Ketchikan, Alaska*, 23 September 2005, http://www.sitnews.us/0905news/092305/092305_op_alaskan_road.html.
- 26 Vicki D. Hall, "Operation Alaskan Road," *Engineer* (January-March 2008): pp. 47-50.
- 27 Fred Baker, "Troops Create Lifeline to Alaskan Village," *DoD News*, 30 August 2007, <https://archive.defense.gov/news/newsarticle.aspx?id=47243>.
- 28 General Accounting Office, *Innovative Readiness Training Program Needed for Better Compliance* (1998), <https://files.eric.ed.gov/fulltext/ED418317.pdf>.
- 29 Hall, "Operation Alaskan Road."
- 30 Perry, "Marines Take Long, Hard Road."
- 31 Martens, "Leaving a Warm Touch on the Arctic Circle."
- 32 Staff Sgt. Balinda O'Neal Dresel, "Service Members Unite to Provide Assistance to Isolated Village in Alaska," *U.S. Army*, 27 April 2017.
- 33 IRT, "The Newtok to Mertarvik Innovative Readiness Training Documentary," *U.S. Department of Defense*, <https://www.youtube.com/watch?v=gcTus97OTp4>.
- 34 Joseph Simms, "Reservist's Provide Medical Care for Underserved Regions of Alaska through Arctic Care 2018," *Air Force Medical Service*, <https://www.airforcemedicine.af.mil/News/Display/Article/1498055/reservists-provide-medical-care-for-underserved-regions-of-alaska-through-acti/>.
- 35 "Combating the Cold: IRT Arctic Care 2018 Kicks Off," *Marine Corps Forces Reserve*, 16 April 2018, <https://www.marforres.marines.mil/DesktopModules/ArticleCS/Print.aspx?PortalId=116&ModuleId=1&Article=1494175>.
- 36 Desroches, "Old Harbour Infrastructure Project"; Dresel, "Service Members Unite."
- 37 Reese, "Marine, Sailors, Soldiers."
- 38 Watts, "IRT Old Harbor's Runway Extension."
- 39 DND, Canadian Forces Northern Employment and Support Plan (November 2012), p. 22.
- 40 On Reg Saunders, see Hugh Dolan and Adrian Threlfall, *Reg Saunders: An Indigenous War Hero* (Sydney: NewSouth, 2015).
- 41 Australian Department of Defence (DoD), "Army Aboriginal Community Assistance Program: Information Brief," http://www.defence.gov.au/publications/080502_AACAP.pdf.
- 42 Department of Infrastructure, Regional Development and Cities, "Defence: Regional Australia - a Stronger Economy Delivering Stronger Regions, 2018-2019," *Government of Australia*, https://infrastructure.gov.au/department/statements/2018_2019/.../defence.aspx.
- 43 Noel Beutel, "AACAP: The Untold Story," *Australian Journal of Multi-Disciplinary Engineering* 6/2 (2008): 238. See this article for details on funding and scope from 2000-08.
- 44 DoD (Aust.), "Army Aboriginal Community Assistance Programme Background Factsheet," <https://www.defence.gov.au/publications/docs/AACAPBackgroundfactsheet.pdf>.
- 45 Department of the Prime Minister and Cabinet (PM&C) and the Australian Army, *Army Aboriginal Community Assistance Programme (AACAP), 2017 Review: Realising the Potential, Government of Australia*, 2017, <https://www.niaa.gov.au/sites/default/files/publications/AACAP-review-october-2017.pdf>.
- 46 DPM&C and Australian Army, *AACAP 2017 Review*.
- 47 Australian Army, "Army Indigenous Supplement to the Defence Indigenous Handbook," <https://www.defence.gov.au/publications/docs/ArmyIndigenousSupplement.pdf>.
- 48 DoD(Aust.), "Reconciliation Action Plan, 2015-2018," *Government of Australia*, www.defence.gov.au/Diversity/_Master/docs/drap/DRAP.pdf.
- 49 Serge DeSilva-Ranasinghe, "Indigenous Nation Building: The Army Aboriginal Community Assistance Programme," *Policy* 30/4 (2014-15): pp. 29-35.
- 50 Serge DeSilva-Ranasinghe, "Up North with the Army: National Building with Indigenous Communities," *Policy* 31/1 (2015): pp. 51-54.
- 51 Australian National Audit Office, *Army Aboriginal Community Assistance Program Performance Audit*, 2010, https://www.anao.gov.au/sites/default/files/ANAO_Report_2010-2011_19.pdf?acsf_files_redirect.
- 52 Captain Brad Willis, "Humanitarian Engineering in Indigenous Australia," Presented at the Year of the Humanitarian Engineering Workshop, Darwin, 3 November 2011, *ISSUU Engineers Australia*, https://issuu.com/engineersaustralia/docs/willis_aacap_-_darwin_3_nov.
- 53 The ADF Also Offers Health Care to Indigenous Communities through Exercise Kummundoo. See Memorandum of Understanding, Royal Australian Air Force and National Aboriginal Community Controlled Health Organisation, 2015, <https://www.naccho.org.au/about/governance/partnerships/raaf/>.
- 54 DPM&C and Australian Army, *AACAP 2017 Review*.
- 55 DPM&C and Australian Army, *AACAP 2017 Review*.
- 56 DoD (Aust.), "Army Aboriginal Community Assistance Program: Information Brief."
- 57 DPM&C and Australian Army, *AACAP 2017 Review*.
- 58 DeSilva-Ranasinghe, "Indigenous Nation Building," pp. 29-35.
- 59 Beutel, "AACAP," p. 239.
- 60 PM&C, Aboriginal Affairs and Reconciliation Division, South Australian Government, "Update: Progress on the Anangu Pitjantjatjara Yankunytjatjara (APY) Lands December 2013," *Government of South Australia*, https://www.dpc.sa.gov.au/__data/assets/file/0011/34679/DPC13D07396-Attachment-1-1.pdf.
- 61 AACAP Missions Also Rely on Extensive Logistical and Transport Support from Across the ADF. See DoD (Aust.), "AACAP: Information Brief."
- 62 Beutel, "AACAP," pp. 237-242.
- 63 South Australian Government, "Progress on APY Lands."
- 64 Australian Army, "Army Aboriginal Community Assistance Factsheet," November 2015, www.defence.gov.au/publications/docs/AACAPBackgroundfactsheet.pdf.
- 65 Shalailah Medhora, "From the Red Earth of Titjikala Rises a Legacy Built on Trust and Respect," *The Guardian*, 16 July 2015, <https://www.theguardian.com/australia-news/2015/jul/16/from-the-red-dirt-of-titjikala-rises-a-legacy-built-on-trust-and-respect>.
- 66 Samantha Jonscher, "Army and Yalata Aboriginal Community Face Off on Footy Pitch, Work Together to Improve the Remote Community's Outcomes," *ABC News*, 18 August 2018, <http://www.abc.net.au/news/2018-08-19/army-helps-to-build-better-future-in-yalata/10122782>.
- 67 Captain Holly Goodwin, "Army Aboriginal Community Assistance Program (AACAP) 2018 - Yalata, South Australia," *The Cove*, 18 June 2019, <https://cove.army.gov.au/article/army-aboriginal-community-assistance-program-aacap-2018-yalata-south-australia>.
- 68 Northern Territory Government, "Defence and National Security Strategy 2018," *Northern Territory Government*, <https://business.nt.gov.au/business/.../nt-defence-and-national-security-strategy-2018>.
- 69 DPM&C and Australian Army, *AACAP 2017 Review*.
- 70 Lt. Colonel Renée Kidson, "Building Bridges in the South West Pacific: Harnessing Army's Part-Time Construction Engineers," *The Cove*, 16 August 2019, <https://cove.army.gov.au/article/building-bridges-the-south-west-pacific-harnessing-armys-part-time-construction-engineers>.
- 71 Department of Defence, "Department of Defence, 20 Years of Serving the Community," *Government of Australia*, <https://www.defence.gov.au/annual-reports/16-17/Features/20YearsServingCommunity.asp>.
- 72 DeSilva-Ranasinghe, "Up North with the Army."
- 73 DPM&C and Australian Army, *AACAP 2017 Review*.
- 74 DeSilva-Ranasinghe, "Indigenous Nation Building," pp. 29-35.
- 75 Medhora, "From the Red Earth."
- 76 Jonscher, "Army and Yalata Aboriginal Community."
- 77 CDS Initiating Directive, p. 7.
- 78 Crown-Indigenous Relations and Northern Affairs Canada, "Canada's Arctic and Northern Policy Framework," <https://www.rcaanc-cirnac.gc.ca/eng/1560523306861/1560523330587>.
- 79 Derek Neary, "We need to be pushing for more," *News/North*, 22 April 2019.
- 80 Lieutenant Ryan Perry, 4 Engineer Support Regiment, "Exercise NIHILO SAPPER Abandons 'the Same Old Thing' and Builds Not Only a Bridge but Community Spirit," 12 January 2016, <http://www.army-armee.forces.gc.ca/en/news-publications/national-news-details-no-menu.page?doc=exercise-nihilo-sapper-abandons-the-same-old-thing-and-builds-not-only-a-bridge-but-community-spirit/ij5bh>.
- 81 Adam Lajeunesse, "Unarmed Warships: What Are the AOPS For?" *Canadian Global Affairs Institute*, June 2018.
- 82 Charlie Evalik, President, Kitikmeot Inuit Association, and Charlie Lyall, President, Kitikmeot Corporation, "Submission to the Senate Standing Committee on National Security and Defence: Canadian Sovereignty, the Military and Infrastructure Development in the Inuit Homeland," December 2010.
- 83 Mary Simon, *Interim Report on the Shared Arctic Leadership Model* (2016), <https://www.rcaanc-cirnac.gc.ca/eng/1481656672979/1537886690726>.
- 84 CDS Initiating Directive, 6.
- 85 Medhora, "From the Red Earth."



DND photo by Corporal Tina Gillies/WT2010-0136-13

Chief of Land Staff (CLS) Lieutenant-General Peter Devlin and CWO Giovanni Moretti, Army Sgt-Major visits The National Support Element (NSE) during Battle Inoculation Stand during exercise REFLEXE RAPIDE at Canadian Forces Base Wainwright, AB, 5 September 2010.

Deciphering the Roles of Chief Petty Officers/ Chief Warrant Officers within Command Teams

by **Necole Belanger**

Chief Warrant Officer (CWO) Necole Belanger, MMM, CD, is currently the Command CWO for the Canadian Forces Intelligence Command (CFINTCOM). She joined the Canadian Armed Forces in 1987 as a Military Police Officer and since transitioning to senior appointments in 2013 has held such jobs as the Strategic Joint Staff CWO, the Strategic Response Team CWO for Operation HONOUR, the 16 Wing CWO, and the Canadian Defence Academy CWO. She is currently the Command Chief Warrant Officer for the Canadian Forces Intelligence Command. CWO Belanger holds a bachelor's degree with first class distinction from the Royal Military College and a two-year diploma in Law and Security Administration from Loyalist College of Applied Arts and Technology. She has also authored several articles on leadership, including *The Accidental Strategic CWO*, *Inclusive Leadership: If We Build It Will They Come*, and *Being a Member of the Profession of Arms: A RCAF CWO's Perspective*.

According to *Beyond Transformation: the Chief Petty Officer, First Class/Chief Warrant Officer (CPO1/CWO) Strategic Employment Model (SEM)*, a command team construct is generally defined as "... a distinguishable set of two or more people who entered, dynamically, interdependently and adaptively toward a common and valued goal/objective/mission, who have been assigned specific roles or functions to perform and who have a limited life-span of membership."¹ *Beyond Transformation* goes on to define this construct as "the combination of a Commander and CPO1/CWO" with their individual skill sets being merged together to form the final level of leadership, either at the tactical, operational, or strategic level.² While it is recognized that other command teams exist at lower levels, I will focus solely on the senior appointed Chief Petty Officer/Chief Warrant Officer (CPO1/CWO).



Then Lieutenant-General Wayne Eyre, Commander of the Canadian Army, speaks to participants of the Canadian Armed Forces Small Arms Concentration at the Connaught Ranges and Primary Training Centre in Ottawa, Ontario, 21 September 2019.

This article challenges the assumption that CPO1/CWOs are ready to fulfill command team roles beyond the tactical level immediately upon appointment. I think we have a gap and a missed opportunity to enhance the effectiveness of the command team, particularly for those CPO1/CWOs in key institutional appointments where they may feel out of their element because of the dichotomy that exists between military chain of command that most are familiar with and unity of command and the system of government at the strategic or institutional level. This paper is designed to highlight the complexities associated with each senior appointed level of leadership within the CPO1/CWO Corps and could be a beneficial tool for those currently serving as senior CPO1/CWOs. It will also serve as a good foundation of study for future senior CPO1/CWOs. It will compare and contrast the different roles and complementary strengths of the officers and non-commissioned members (NCMs) who come together to form these teams and I hope that by building on the points of view presented that you can increase the effectiveness of your leadership team relationship.

An Interesting Dynamic

While acknowledging the importance of any command team’s ultimate leader with authority – the Commander – we need to expand our focus beyond this unitary position so

“This dynamic does not exist anywhere else in government or even in big business, which could explain why CPO1/CWO roles have remained elusive and difficult to codify.”

that roles and responsibilities of appointed Commanders and CPO1/CWOs remain clear.³ Commanders’ roles are easily defined by their accountabilities, responsibilities, and authorities (ARAs) and clearly laid out in law. For CPO1/CWOs it isn’t that simple. CPO1/CWOs have no authority by themselves; they derive their authority from their Commander and exercise it in the Commander’s name. This does not mean CPO1/CWOs lack authority or are powerless; they are definitely not. CPO1/CWOs rely on their personal power within the organization to undertake activities on their Commander’s behalf. Personal power is described in leadership doctrine as a source of influence a person has over his followers and is based on strength of character, confidence, and competence that individuals acquire in the course of their development.⁴ It is the reliance on this personal power and the authority the CPO1/CWO derives from their individual Commanders that makes for an interesting relationship. This dynamic does not exist anywhere else in government or even in big business, which could explain why CPO1/CWO roles have remained elusive and difficult to codify.

Most CPO1/CWOs have heard their roles portrayed as “buttons and bows” or the “3Ds” (dress, deportment, and discipline), co-stewards of the profession of arms, guardians of the NCM corps, and, as the advisor and confidant to the Commander.

While these terms largely express some of what we have traditionally done, there remains a lack of consistent understanding as to the potential to enhance the command team through a more fulsome spectrum of how CPO1/CWOs can, could, and should be leveraged from within our own ranks as well as at the officer level. For the most part, our roles do not change significantly; what changes is the organizational influence we exert, and the manner in which we choose to exercise these functions varies depending on the positional level we are filling and the “value-added” we can bring to the command team through our unique perspectives and experiences. Our scope of engagement at each level should focus on leading the institution and align with our Commander’s ARAs. Developing CPO1/CWOs who are competent at all three levels of leadership and able to not only lead people, but lead the institution, is imperative and it becomes even more vital at the strategic level. Complicating this fact is that attributes that make a CPO1/CWO a highly effective tactical leader do not always translate across the other levels of leadership, and in fact, in some cases, may actually inhibit their thinking or acting and being effective at the operational and strategic levels.

“While approaches will reflect individual personalities, and methods may differ to complement their commander, strategic level CPO1/CWOs fill many roles, but I consider three mutually supporting ones to be essential: as connectors, they help link the grassroots with the strategic, ensuring implications, issues, and ideas are aligned and understood up, down, and across the chain; as advisors, they provide critical perspectives and act as sounding boards for many, especially for

complex decisions; and, as communicators, they reinforce commanders’ intent while providing a conduit up for voices in the field. Critical for success in all at this level are organizational understanding, wide networks, and well developed interpersonal skills, along with a solid appreciation of institutional issues.”

– Acting Chief of Defence Staff
Lieutenant-General Wayne Eyre

Former Canadian Forces Chief Warrant Officer (CFCWO) Kevin West, in his 2010 Royal Canadian Air Force (RCAF) Journal article “The Role of the Chief Warrant Officer within Operational Art,” touched on the fact that “without clear definitions of roles..., a grey area will continue to exist between the [officer and NCM] corps”⁵ at levels beyond the tactical sphere. It is imperative that the institution guard against its dilution by establishing stringent criteria by which the establishment of one strategic occupation called the “CPO1/CWO Corps” will be created. The single most important criterion within the SEM Guidance Document was to ensure CPO1/CWOs were paired with Commanders to form command teams.⁶

To clarify the lack of understanding regarding the roles of the senior-most CPO1/CWO within the different levels of employment the CAF moved toward competency-based human resource (HR) practices. “In recent years the CAF has taken steps to modernize this career management system. One of these initiatives has been the development of leader profiles (LP) for executive level positions.”⁷ However, even these do not quite



DND photo

CWO Crystal Kramer, Military Police Command Team at Tactical Level (Tactical Leadership Team).

capture all the nuances of the command team concept and tend to be more applicable to individuals in leadership roles. Thus, we find ourselves in a quandary: when the roles are too explicit they limit a Commander's ability to make appropriate use of their CPO1/CWO and develop a cohesive team that fits their requirements; too generic or broad, they provide no real clarification or defined arcs, and consequently a discrepancy is evoked.⁸

“As a CPO1/CWO, progressing from the tactical, operational and to strategic levels will impose an increased demand in the abilities and commitment of the Chief Corps. Our role as chiefs is to “Set the Example” of unique values and behaviours that are intended to deliver operational professionalism and leadership proficiency. What we do will always be about our people, regardless of the level.”

CPO1 Gilles Grégoire
Canadian Armed Forces Chief
Warrant Officer

CPO1 Grégoire is adamant in carrying on with the work of former CAFCWOs. He recognizes this discrepancy and wants to ensure that that CPO1/CWOs possess enhanced skill-sets and the necessary cognitive knowledge to take on the responsibilities demanded of them within each of the three senior appointment levels: Post Tactical Leadership Team – Entry (PTLT – E), Post Tactical Leadership Team – Master (PTLT – M), and Strategic Leadership Team (SLT). Having occupied every leadership level within the CAF, CPO1 Grégoire knows better than most that when CPO1/CWOs cross the threshold from leading people to leading the institu-

tion their roles and responsibilities must shift from the technical competencies they developed in their trades to broader leadership competencies, critical thinking, strategic planning, complex problem solving and effective communications. Along with shouldering greater responsibilities, the institution requires advice and input from CPO1/CWOs because of the unique position they occupy within the framework of the CAF. Senior CPO1/CWOs are expected to “provide knowledgeable input, grounded in critical thinking, supported by ethical reasoning, contextualized in practical experience and professionalism.”⁹ In order to address this discrepancy the *CPO1/CWO Preferred Path* was created. This model is based on the acquisition of sequential professional military education (PME) knowledge since sequencing of instruction is one of the most important issues in the application of learning theory.¹⁰

The author designed the current *CPO1/CWO Preferred Path* (Figure 1) to augment the experiences CPO1/CWOs bring to the table and better prepare them for the complexities of leading the institution and advising Commanders at the strategic level. The intent of this conceptual model was not to force NCMs into obtaining diplomas and degrees but rather to lay out a more deliberate path and sequence of developing expertise and gaining experience. Past practices often separated or emphasized one over the other. While experience can, it does not always provide all the necessary skills needed for the next appointment while education alone only provides knowledge, not necessarily understanding or application. There is no clear answer as to which is the most appropriate or successful because there is not a “one size fits all”

“we find ourselves in a quandary: when the roles are too explicit they limit a Commander’s ability to make appropriate use of their CPO1/CWO and develop a cohesive team that fits their requirements; too generic or broad, they provide no real clarification or defined arcs, and consequently a discrepancy is evoked.”

deliberate path and sequence of developing expertise and gaining experience. Past practices often separated or emphasized one over the other. While experience can, it does not always provide all the necessary skills needed for the next appointment while education alone only provides knowledge, not necessarily understanding or application. There is no clear answer as to which is the most appropriate or successful because there is not a “one size fits all”

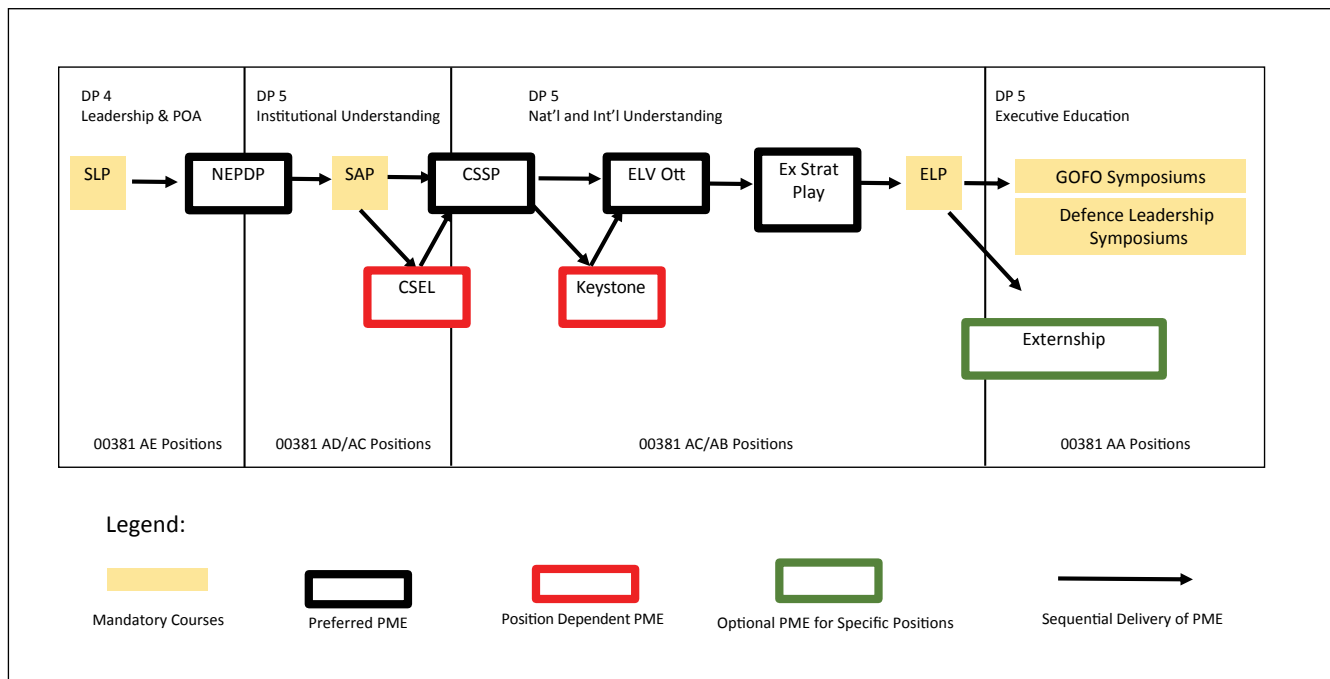

Figure 1: The CPO1/CWO Preferred Path

solution. Every CPO1/CWO is different. What is most important is the ability to learn and practically apply the knowledge coupled with an open-minded attitude toward new ideas and concepts, which is exactly how the *Preferred Path* is set up. It addresses a systemic gap and offers a better way to develop CPO1/CWOs. The CAF needs us to be productive at every level and adaptive to the learning curve that exists at each level. You won't always be invited to have a seat at the table, so when you do have that opportunity, you must make it count and not only bring your ideas but opinions and advice. Adding value and enhancing effectiveness comes from a combination of expertise, experience, and education.

The Three Environments and the Three Leadership Levels

There is little doubt that the Royal Canadian Navy (RCN), the Canadian Army (CA) and the Royal Canadian Air Force (RCAF) employ their CPO1/CWOs differently. For example, the RCN employs the Command Team Triad (Commander, the Executive Officer (XO) and the Coxswain), while the CA leadership team is composed of the Commanding Officer (CO) and the Regimental Sergeant Major (RSM). The RCAF employs a CO with a Squadron Warrant Officer (SWO). At Headquarters level, there may also be the insertion of staff positions like the Chief of Staff (COS) or Deputy Commanding Officer (DCO) that bring an additional dynamic to the command team. Regardless of the environmental uniform the CPO1/CWO wears, one thing is certain – for any of these relationships to work the CPO1/CWO must play a complementary role to their Commander and they must excel at the people part of leadership: connecting, communicating, motivating, etc. while also being prepared to advise and lead the institution.

At the PTLT-E level, it is usually the CPO1/CWO who has the greater experience and technical expertise as well as an understanding of NCMs and thus their advice is of particular value to the Commander. The CPO1/CWO is relied upon heavily by the Commander to ensure the sailors, soldiers, and aviators are trained and developed and motivated and well cared for so that the organization is an effective fighting force. A PTLT-E CPO1/CWO almost always takes a “hands on” approach. Their focus is mostly on leading people and the manner in which leadership is exercised at this level can best be described as “down and in,” but there exists some operational influences. In this type of relationship, the Commander and the CPO1/CWO are almost always together in order to contribute to mission success. For the most part, CPO1/CWOs excel at this level of leadership and accordingly their roles should not change.¹¹

At the PTLT-M level, it becomes the officer who may possess greater experience, stemming in part from their professional development (PD) that includes not only their occupational requirements but also leadership, strategic planning, critical think-

ing, and execution of operation as well as extensive experiential opportunities through exercise, employment, and deployment. Courses such as the Joint Command and Staff Program (JCSP) and the National Security Program (NSP) groom these future leaders for leadership of the institution. However, the experiential advice of the CPO1/CWO is still of vital importance and brings a distinct and unique viewpoint because CPO1/CWOs view problems from a different perspective than officers.¹² At this level you must be creative, a visionary, and extremely confident in your abilities to provide the proper advice that assists your Commander in taking risks. Furthermore, your scope of responsibilities is greater than at the PTLT-E level and you must consider a wider range of potential outcomes. You start to shift from “doer” to “delegator” and learn to lean on and trust subordinates. As a member of this team, the CPO1/CWO should be venturing out on their own on occasion to communicate the Commander's intent and to engage audiences within their organization. It is at this level that we start to see a shift from leading people to leading the institution, which the Deputy Director Academics at the Canadian Forces College, Dr. Alan Okros, describes as occasionally addressing “inter-related domains across, ‘up and out,’ including into societal and political arenas in which the profession of arms must function.”¹³ In a nutshell, operational leadership is about mission implementation and getting things done.

“The CPO1/CWO is relied upon heavily by the Commander to ensure the sailors, soldiers, and aviators are trained and developed and motivated and well cared for so that the organization is an effective fighting force.”

At the SLT level problems are not controlled by tactics, techniques, and procedures (TTPs). More often than not, problems are “wicked” in nature and are rarely as straightforward as dilemmas faced at the tactical level. CPO1/CWOs must possess a broader institutional and political understanding so that they do not make snap decisions that can make a problem worse. They must focus on framing the problem before attempting to solve it. This is a difficult feat to master since CPO1/CWOs are accustomed to reacting immediately and are used to feeling that they have all the answers. At the strategic level the Command CPO1/CWOs set the tone for the entire NCM Corps, and along with their institutional level Commanders, they affect the entire culture of the CAF. They set direction vice drive execu-

tion. They must be outstanding examples and be models of ethical, professional, and technical competence. Effective Command CPO1/CWOs are combined team builders who must understand the joint, interagency, and multinational environment. They must be “deft influencers and organizers, with a keen appreciation for the mechanics of power and the social environment in which they operate.”¹⁴ As such, almost every “task requires more coordination, takes longer, has a wider impact, and produces longer-term effects”¹⁵ than operational or tactical decision-making. A strategic CPO1/CWO remains focused on the “down and in” while simultaneously operating in the “up and out” framework, which helps shape broader organizational systems and processes. In other words, strategic leadership for CPO1/CWOs is about helping to position the organization to be competitive in the long run. It isn't so much about individual environments as it is about the CAF as a whole. More often than not a strategic level CPO1/CWO will

DND photo by Corporal Lynette Ai Dang



Commander Mark O'Donohue, the Commanding Officer of HMCS *Calgary*, Cdr Meghan Coates, the Executive Officer of HMCS *Calgary* and Chief Petty Officer First Class Mark Chambers, the Coxswain of HMCS *Calgary*, stand on the ship's forecandle in Jakarta, Indonesia during Operation PROJECTION, 2 July 2021.

engage with military and civilian stakeholders outside of their command structure, independently of their Commander, although the CPO1/CWO's priorities will always line up directly with those of their Commander's. Additionally, these CPO1/CWOs spend

less one-on-one time with troops and thus use the privilege of speaking to a wide variety of audiences to communicate the commander's intent. We call this a privilege because the Commander must entrust their CPO1/CWO with this role.

Senior Appointed CPO1/CWO Command Teams

Contributing Regiment	RCN	CA	RCAF	PAN CAF	NATO	Deployed Ops	Res F
Level 0 – Institutional	–	–	–	1	–	–	–
Level 1 – Strategic Strategic Leadership Team – (SLT)	1	1	1	5	–	–	–
Level 2 – Operational Post-Tactical Leadership Team – Master (PTLT-M)	2	5	2	–	–	–	3
Level 3 – Tactical Post Tactical Leadership Team – Entry (PTLT-E)	6	11	13	27	6	5	18

Author: CWO Belanger

Table 1: Senior Appointed CPO1/CWO Command Teams [Data furnished by the CPO1/CWO Corps CWO, CWO Jenny Godin].

NOTE: Specific Level 3 - PTLT-E positions are undergoing assessment to determine whether they will migrate to a Level 2 – PTLT-M. Presently, these positions are accounted for under PTLT-E.

The Challenges of Navigating from the Tactical to the Operational and Strategic Level

Preparing CPO1/CWO to assume leadership roles at the three different levels can be extremely challenging. First and foremost, employment opportunities beyond the tactical level for CPO1/CWOs are still limited in scope. Second, is our own inability to articulate a clear understanding of our roles at these different levels. Last and perhaps most important, is that some are still holding on to the pervasive attitude that Commanders and CPO1/CWOs should only be paired together at the tactical level.

As an institution, we need to provide additional exposure for our NCMs into more complex positions to equip them with the knowledge they will require at the operational and strategic level. As a corps, we must not only want to step outside our comfort zone and embrace different leadership roles but be prepared and encouraged to do so. For instance, as the chief disciplinarian of a unit, an individual must shift his or her focus to different tasks at the operational level, such as spending more time focusing on external matters, and playing a new social role in the organization. A common mistake made by tactical level leaders is to continue to lead at the next level without changing their leadership style. “Focusing on your strengths is required, but improving your weaknesses has the potential for the greatest gains... Leaving your comfort zone involves risk, however, and when you are already doing well

the temptation to stick with the status quo can be overwhelming, leading to stagnation.”¹⁶ Even if CPO1/CWOs have the ability to adapt to a new role, they still have to deal with the legacy of the roles that they previously played in the organization. For example, if the CPO1/CWO has earned the reputation as a “hard-edged disciplinarian” people within the organization may hold deep-seated attitudes that make it extremely difficult for that person to undertake a major role shift.¹⁷ Finally, the biggest hurdle is winning over the hearts and minds of those who believe we have no advisory role to play at the operational or strategic level.

This will only be achieved if we as individuals and as a Corps focus on personal and professional growth and if we can articulate unequivocally exactly how we add value and complement our Commanders.

“Commanders benefit greatly from the unique perspectives, experience and advice as well as a “challenge function” that CPO1/CWOs can provide as command team partners. This must not only be developed but encouraged before senior NCMs are assigned to institutional level command team roles so that they are confident and ready to make the most of the opportunity to guide, advise, influence, communicate, and implement the Commander’s vision and decisions.”

RAAdm (Ret’d) Jennifer Bennett

“A common mistake made by tactical level leaders is to continue to lead at the next level without changing their leadership style.”



Then Defence Champion for Women, Rear-Admiral Jennifer Bennett, addresses the audience during an event for International Women's Day, held at the Perley-Rideau Veteran's Health Centre, 6 March 2018, in Ottawa.

Command Teams Working Together for a Common Vision Can Be an Incredible Thing

It has been said that it is lonely at the top, but it shouldn't be because leaders are more effective when they are supported by a team. Leadership of a unit, a formation, or a command is simply too big for any one person. Renowned leadership author John C. Maxwell points out in his bestselling book *Leadership Gold*, "why be on the fringes of your strength zone when you have a chance to be right in the centre by discovering your uniqueness and then disciplining yourself to develop it."¹⁸ Strong command teams require the development of a partnership based on trust, a common vision and open communication. There must also be an understanding of the strengths that each brings to the partnership as well as areas where one can complement or strengthen the other. Bringing the Commander and CPO1/CWO together "results in a team in which the whole is greater than the sum of the parts."¹⁹

"Strong command teams require the development of a partnership based on trust, a common vision and open communication."

"Command team leadership is vital to the success of the RCAF at all levels. I have been spoiled during my career with exceptionally gifted and intuitive RCAF CWO Partners who have purposefully advanced organizational goals and objectives, demonstrated impeccable role modeling, while remaining tuned to the disposition and vibe of all personnel."

LGen Al Meinzinger
RCAF Commander

The first thing a CPO1/CWO needs to do when being appointed to a command team, regardless of the level, is meet with their Commander and establish a good relationship; the second is to vie for that person's support. It is here that the Commander will lay out the division of labour or set the ground rules that you will be expected to play by. A common

vision and close communication enable decisive and formidable cooperative action. You will know when you have achieved this state of complementarity because your Commander will provide you with a "free runway"²⁰ to do what you need to do to advance



DND photo by LS Erica Seymour/RP26-2019-0038-024

RCAF Commander, Lieutenant-General Al Meinzinger (left) and RCAF CWO, CWO Denis Gaudreault speak with the troops during their visit to Operation REASSURANCE-Air Task Force-Romania, 15 December 2019 at the Mihail Kogălniceanu Airbase.



DND photo by Corporal Brian Lindgren

Commander of Joint Task Force – IMPACT / Task Force – Central (JTF-I/JTF-C), Brigadier-General Michael Wright, with the assistance of A/JTF-I/TF-C Chief Warrant Officer, CWO Richard Coltart, say goodbye to ROTO 3 members who served during Operation IMPACT, Joint Task Force – IMPACT / Task Force – Central, at Camp Canada, Ali Al Salem Air Base, Kuwait, 16 February 2021.

the mission on their behalf. It is simply not enough that you and your Commander understand your relationship; subordinate Commanders and NCMs must also understand it. In the end, a Commander's support will be pivotal to your leadership success; not only because Commanders are the most powerful person in that organization, but because they deal with the big picture on a daily basis. Therefore, it is imperative that you possess a common vision and close communication which will enable decisive and formidable cooperative action and increase effectiveness.

Communication, mutual respect, common vision, and trust are also paramount. The most effective command teams have not only a strong connection and rapport but possess open, effective, and ongoing communication. Two-way feedback is a huge part of the communication cycle. Do not be afraid to communicate candidly and frequently with your Commander. These officers would not ask for your advice if they didn't want to hear the ground truth. This is their way of inviting you to push back before the decision is made. "This is never disloyalty; however, questioning the decision afterward is not good teamwork."²¹ You are essentially the eyes and ears of the Commander and your discussions are on behalf of the personnel within your unit, on your wing, within your formation, or at the command level. You are perfectly placed within the institution to obtain the pulse of the organization you serve.

Trust is built on honesty and dependability. You must deliver what you say you will, which in turn will lead to you influencing up and down the chain of command. Trust builds over

time through mutual respect, a shared vision, and common experiences. Communication builds trust by keeping others informed. A CPO1/CWO can foster trust by articulating the Commander's intent and guidance, with specific focus on the "why." Sustaining trust depends on meeting expectations, thus you must be extremely careful not to communicate conflicting direction when you communicate via the "CPO1/CWO net."

The CPO1/CWO's Role in a Non-Complementary Team

While the CPO1/CWO Corps does an excellent job at trying to match CPO1/CWOs with a specific organization as well as with the appropriate Commander, sometimes compatibility is difficult, if not impossible to achieve. As stated earlier, compatibility and a strong partnership begins and ends with trust. A good indication of a lack of trust is if your responsibilities haven't evolved past the tactical level. For example, at the strategic level, your Commander will only entrust you with decisions concerning NCMs; they do not ask for your advice or your input is considered as an afterthought; you are rarely at the table; and, you are likely required to seek approval on everything you do with close scrutiny and micromanagement. No matter how challenging the relationship may be, it is vital that both partners find a way to balance perspectives and inputs to make the relationship work. You cannot leave the nurturing and tending of this relationship to chance. There is one appointed Commander and the CPO1/CWO's job is to support this officer up to the point where support becomes unethical;

until that point, however, the CPO1/CWO must directly address the lack of a productive relationship.

“CPO1/CWOs need to adapt their style of leadership to the level at which they are operating to compliment that of their command team partners. They must also be comfortable in uncomfortable situations.”

CWO (Ret'd) Denis Gaudreault
Former RCAF CWO

If you are unsure of your Commander's goals, objectives, and desired outcomes, it is imperative to set up a one-on-one meeting as early as possible to gain a better understanding of how they work and how you can best provide support. “With opportunities come risks. Don't be afraid to take them. It is in moments of risk that the greatest leaders are born.”²² You may have to take the lead to inform your Commander about what you bring to the table that can enhance the effectiveness of the team and the organization, how best to use your expertise and experience, and how your inputs and perspectives will help him or her to lead the organization. If you have done all this and you feel you are still being underutilized and do not have a “free runway” to operate you will need to carve out a niche for yourself, being careful not to expand into areas where you have limited knowledge and no authority. If you overstep the authorities the Commander has provided to you the command team will collapse and the relationship will no longer be productive in any form. The only ones who suffer when this happens are the subordinates, both subordinate officers to the Commander, and subordinate NCMs to the CPO1/CWO.

“If you overstep the authorities the Commander has provided to you the command team will collapse and the relationship will no longer be productive in any form.”

Conclusion

The strategic vision of the Commander includes a wider institutional view of where the organization is going, while CPO1/CWOs bring their experience and understanding of the work that goes into making every decision happen and implementing the vision or mission. Through their own careers, CPO1/CWOs have likely seen the issues and have an understanding about how subordinates do their work and how to get the job done effectively and efficiently. “The effect of these two functions working together to solve problems is a force multiplier in any organization. What it does is take the best of both the need to see the big picture with fresh eyes and marries it up with understanding the details and the ‘how’ from the ground up.”²³ CPO1/CWOs can serve as force multipliers if they direct their efforts to those things that their Commanders need them to focus on. CPO1/CWOs must remember that it isn't about them; it is their role as part of a team. You are there because you bring technical competency, professionalism, maturity, experience, and most importantly, a distinctive perspective and voice to the table. Your ability to network and the significant personal power you possess will augment your Commander's understanding of the institution and the big picture and their ability to achieve the mission. One of your many roles, regardless of whether you are exercising direct leadership at the tactical, operational, or strategic level, is to bring the perspective of the NCMs and your understanding of how things get done. Your voice is essential and adds value to one of the most crucial team concepts in the CAF and the occasion will be lost if you don't take advantage of the opportunity to fulfill your role.



NOTES

- 1 Chief of Defence Staff, *Beyond Transformation: The CPO1/CWO Strategic Employment Model* (Ottawa: Chief of Force Development, 2021), Section 2.4.
- 2 *Ibid.*
- 3 A. C. Okros, “The Command Team: A Valuable Evolution or Doctrinal Danger,” *Canadian Military Journal* 13, no. 1, Winter 2012.
- 4 *Ibid.*
- 5 Kevin West, “The Role of the Chief Warrant Officer within Operational Art,” *The Canadian Air Force Journal* 3, no. 1 (Winter 2010), 47–49.
- 6 Chief of Defence Staff (CDS) Letter, 6 April, 2016, *CDS Strategic Employment Model (SEM) Guidance document*.
- 7 DGMPRA, Leader Profiles, *Process and Methodology from Conception to Validation*. March 2019.
- 8 Terwan Crawley, CSM, *The Officer/Non-commissioned Officer Relationship*, excerpt from paper published by US Sergeant Major Academy. Retrieved on 6 April 2020 from <http://ncoguide.net/the-officernoncommissioned-officer-relationship/amp/>.
- 9 Canadian Armed Forces (2017), Chief Petty Officer/Chief Warrant Officer Strategic Employment Model Project (SEM) – Final Report and Recommendation, 14 July 2017.
- 10 S. M. Glynn and F. J. DiVesta, (1977). “Outline and Hierarchical Organization for Study and Retrieval,” *Journal of Educational Psychology* 69, no. 1: 69–95.
- 11 DND, *Beyond Transformation*.
- 12 West. *Operational Art*
- 13 Okros. *The Command Team*
- 14 Richard Martin, “SOT – The Strategy-Operations-Tactics Framework.” Retrieved on 13 April 2020 from <https://alcera.ca/en/articles/SOT-The-Strategy-Operations-Tacica-Framework.php>.
- 15 Headquarters, Department of the Army, Army Leadership, “Be, Know, Do,” FM 22-100. (August 1999). Retrieved on 13 April 2020 from <https://www.armyheritage.org/images/Education/FMs/FM%2022-100%20Aug99.pdf>.
- 16 Garry Kasparov, *Deep Thinking, Where Machine Intelligence Ends and Human Creativity Begin* (Perseus Books, LLC, 2017), 15.
- 17 Stephen A. Miles and Michael D. Watkins, *The Leadership Team: Complementary Strengths or Conflicting Agendas?* (April 2007) Retrieved on 5 February 2020 from <https://hbr.org/2007/04/the-leadership-team-complementary-strengths-or-conflicting-agendas>.
- 18 John C. Maxwell, *Leadership Gold* (Nashville: Nelson Business, 2008).
- 19 Miles and Watkins, *The Leadership Team: Complementary Strengths or Conflicting Agendas?*
- 20 *Ibid.*
- 21 Maxwell. *Leadership Gold*.
- 22 *Ibid.*
- 23 <http://www.leaderschool.ca/blogs--podcast/the-command-team-concept>



P.J.F. Military Collection/Alamy Stock Photo

The HMCS *Toronto* while operating in the Arabian Gulf. HMCS *Toronto* joined the Norfolk, VA based aircraft carrier on a scheduled deployment in support of Operation IRAQI FREEDOM.

War is War: The Relevance and Practicality of The Principles of War for Future Combat

by Tim Gallant

Captain Tim Gallant is an Infantry Officer currently employed as a Light Armored Vehicle Captain (LAV Capt) with the Second Battalion, The Royal Canadian Regiment (2 RCR). He has deployed once as a platoon commander with 2 RCR to Latvia with Op REASSURANCE Roto 9. He holds a BA with a joint major in philosophy and political science from Saint Francis Xavier University.

The more an army lacks war experience... the more it needs to make use of the history of war for its instruction. Although the history of war is no substitute for actual experience it can be a foundation for such experience. In peace times it becomes *the true method of learning war and of determining the invariable principles of the art of war.*

– Marshal Ferdinand Foch¹

Any military officer, as well as any student of military theory, must be familiar with the principles of war. Around the world, military institutions place the principles of war at the foundation of doctrine and teach them to both soldiers and officers. Nevertheless, their basis for knowledge is often flimsy, and their definition either absent or minimal. The critical obstacle to understanding the principles of war is that they vary from country to country. How is one to understand the principles of war without an explanation? What is their basis in knowledge and are they relevant for future combat?

The principles of war have as well come under criticism from the supposed growing complexity of warfare. Concepts such as the revolution in military affairs, unconventional warfare, cyberwarfare, and network-centric warfare, all claim that there has been a growing complexity to war. This article will classify those authors who defend such concepts as futurists. One of their



Marshal of France Ferdinand Foch.

arguments is that the reduced power of the state is the cause of the growing complexity of warfare and that the previously clear distinctions between combatants and non-combatants are becoming significantly unclear.² This article will instead argue that the institutionalization of the principles of war has uprooted them from their basis in the experience of war and that those who predict the radical nature of future combat misunderstand the nature of war.

Military theory's purpose is to assist the commander and his staff during the preparation for and the conduct of combat. All the nuance, and potential innovative nature which a new theory may possess, is fundamentally irrelevant if it does not, in a simple manner, benefit combat effectiveness. As Jim Storr, former professor of war studies at the Norwegian Military Academy and retired British Army Colonel, argues, "military thought concerns the ability to *win* battles, engagements, campaigns, and hence wars."³ Theory assists warfighting because it helps the commander understand what he is engaging in. An artist must know his subject matter if he is to master the techniques of his art. Ignorance does not lead to victory. The practical solution may not sound good nor look reasonable, particularly to those who do not understand the nature of war. If a theory does not accord with the chaos, violence, complexity, and uncertainty of war, then it is useless. The search for a theory that assists effectiveness must account for the fact that such a theory must be effective for what war is. Consequently, theory is essential for the proper conduct of war. The more robust and substantial the theoretical foundations of war are, the more

effective the commander will be when he experiences war. Theory without effectiveness is inappropriate, while effectiveness without theory is blind. Neither leads to success.

Following such a perspective, this article will primarily follow three lines of thought. The first will be an investigation into the history of the principles of war. How were the principles of war conceived? What is their foundation in theory, and does it agree with the nature of war? The second line of thought will be determining and understanding the claims of those futurist authors who argue that war has changed. Primarily, there is a persistent belief that unconventional war is fundamentally different from conventional war. Such a belief has led the United States to introduce three new principles of war to their Joint Doctrine.⁴ Such an addition brings forth an important question: How can new principles of war be discovered? Lastly, in contrast to the second line of thought, the nature of war will be defined. A requirement for a proper understanding of war and to, therefore, achieve victory is to understand its nature. To argue for a split nature of war is a contradiction in terms. War is a single indivisible concept. However, what may be deceiving is that the character of war is in constant change. The swords and shields of Roman legionaries differ drastically from the helicopters, UAVs, and ballistic missiles of contemporary combat. Nonetheless, the nature of war does not change. Carl von Clausewitz, the nineteenth century Prussian theorist of war, convincingly argues war is always an act of force to compel an opposing enemy to adhere to a political will.⁵



Carl von Clausewitz.

The Principles of War

The generation and creation of the principles of war is the result of a historical process. The principles of war are fundamentally a product of the Age of Enlightenment. Throwing off the stubbornness of the Medieval Age, the Age of Enlightenment sought the truths of reality without restrictions. In the fields of biology, chemistry, mathematics, and astronomy, humanity found success. It was only natural that warfighters should be so inclined to venture and find if such truths were discoverable in the realm of war. Nevertheless, Maurice de Saxe, Marshal of the French armies during the War of the Austrian Succession, declared that “war is a science so involved in darkness, and attended with so much imperfection, that no certain rules of conduct can be given concerning it.”⁶ General J. F.C. Fuller, the most productive British writer on the philosophy and history of war throughout the twentieth century, disagreed strongly with such a mentality. To forfeit the search for established truths or wisdom in the conduct of warfare would leave it in the realm of ignorance and superstition. Maurice de Saxe’s line of thought leads to absurdity, and if accepted, then there is no criteria for whether a plan is or is not tactically sound. “Ignorance is not only *always* wrong, but it is *the* evil of the world.”⁷

The principles of war strive to establish a science of war around “organized common-sense” in order to establish truths within the realm of warfare.⁸ If these principles exist, they would necessarily have to be unchanging. To accept, as Canadian doctrine currently does, that there are principles of war but that they are changing, is illogical.⁹ Either there are, or there are not principles of war. Furthermore, the theoretical necessity must form a unity with the necessity for effectiveness. If the principles of war are to be theoretically valuable, they must explain the nature of war and be instrumental to the effective conduct of war. In other words, principles must assist the commander in understanding what war is and make success in combat more likely.

What are the modern principles of war? The Canadian Army’s foundational publication *Land Operations*, published in 2008, contains ten principles of war and defines them as not being “immutable laws” which “must be considered in light of operational circumstances” but that disregarding them “involves great risk and the possibility of failure.”¹⁰ On the other hand, the American Joint Publication 3-0, published in 2018, possesses twelve principles of war and are defined upon the basis of “warfighting philosophy and theory derived from experience.”¹¹ These twelve principles “do not apply equally,” but most of the principles, if not all, are relevant for combat.¹²

“To accept, as Canadian doctrine currently does, that there are principles of war but that they are changing, is illogical.”

To understand the modern principles of war, it becomes necessary to understand their heritage. The genesis of what modern military institutions know as the principles of war begins in the Napoleonic era. Napoleon himself thought that “the art of war possesses some unchanging principles.”¹³ Likewise, reflecting upon his campaigns, he argued that he conducted them “solely in conformity with principles.”¹⁴ Napoleon did not write what these principles were and left that effort to one of his subordinate generals Baron Antoine Henri de Jomini. Regarded along with Clausewitz as one of the greatest military thinkers, Jomini wrote about the geometrical science of warfare, of lines of operations, and logistical capabilities. It is Jomini’s argument for the principles of war, which is essential to this article. He thought that there “is one great principle underlying all the operations of war,” and that is “to throw by strategic movements the mass of an army, successively, upon the decisive points of a theatre of war.”¹⁵ Jomini is one of the first writers to believe that war had principles and that by adhering to them, one would achieve success. His single principle of war lives on in doctrine as either concentration of force or as mass.

The crucial question is, how does Jomini establish this principle? He defines a decisive point as a position that is “capable of exercising a marked influence either upon the result of the campaign or



Napoleon Bonaparte Crossing the Alps.



Baron Antoine Henri de Jomini.

upon a single enterprise.”¹⁶ He then classifies decisive points into three subcategories: decisive geographic points, objective points that are geographically valuable or are valuable in relation to maneuver, and political objective points. Here the military officer can see the development of another principle of war; that of the objective, or in Canadian doctrine the “selection and maintenance of the aim.”¹⁷ What any of the decisive points are in a campaign is dependent upon each army’s lines of operations. At length, Jomini also stresses the advantages of interior lines, a strategy where the centrally located army “can concentrate the masses and manoeuvre with his whole force in a shorter period than it would require for the enemy to oppose to them a greater force.”¹⁸ The commander is in a situation where he can identify the decisive points of the battlefield and achieve relative density against a dispersed but numerically superior enemy.

There is, however, a critical fault with Jomini’s foundation for the principles of war. He makes the grave mistake of insufficiently accounting for the nature of war, namely, its clash of aims and means. The concept of war requires that there are conflicting parties. It involves the dynamic exchange between at least two different aims and their means. “War is nothing but a duel on a larger scale.”¹⁹ Jomini’s lack of reference to combat against a thinking enemy is telling of his mathematical approach.

“this complex nature of unconventional warfare subverts and undermines the principles of war, particularly mass, surprise, and simplicity.”

The scientific method requires a controlled environment and the isolation of factors to observe change and to prove hypotheses; this process is impossible for the concept of war. War is chaos, where endless factors interact with each other. What may make logical sense can counterintuitively be a foolish plan of action because it runs into the enemy’s expectations. War is, at times, illogical and irrational. Indicative of Jomini’s understanding is his statement that “it is quite possible to combine operations skillfully without ever having led a regiment against an enemy.”²⁰ He approaches war more like a mathematic equation rather than a series of violent acts against a thinking enemy. Jomini created a theory with no basis in warfighting.

The Futurist Critique

The principles of war have recently come under criticism. The argument is that they are historically dated and insufficiently account for today’s revolution in military affairs. These criticisms come from futurist theories which detail at length the complexities of modern war with an emphasis on unconventional warfare. The idea of unconventional warfare logically splits the concept of war into the conventional and the unconventional. Here, conventional warfare is defined as state-on-state conflict, i.e., the world wars, while unconventional warfare includes but is not limited to “guerrilla warfare, insurgency and counterinsurgency, counterterrorism, cyberwarfare, cyber-terrorism, information warfare.”²¹

With the introduction of nuclear weapons, the fear of nuclear apocalypse has led the state to renounce the utility of military force. The state had revoked its monopoly on violence through its self-realization that such violence leads to unimaginable destruction. Martin Van Creveld, the renowned Israeli military historian and

theorist, is perhaps the most eloquent of all the futurist authors. He argues that “if states are decreasingly able to fight each other, then the concept of intermingling already points to the rise of low-intensity conflict.”²² Such unconventional warfare enables asymmetric enemies to hide amongst the people and avoid the strengths of a contemporary military’s vast firepower advantage. Therefore, the argument is that this complex nature of unconventional warfare subverts and undermines the principles of war, particularly mass, surprise, and simplicity. Mass is now understood not as the concentration of manpower, which provides the enemy with an excellent target, but now as the massing of effects. Surprise is considered

improbable due to the nature of unconventional warfare’s characteristic of occurring amongst the people. Cellphone messaging and other twenty-first century means of instant communication enables asymmetrical adversaries to report on Allied Forces’ every move and allows them to create a common operating picture from their very living rooms. Likewise, it is the supposed “complex, networked organizational structures,” which prevents simplicity in unconventional warfare.²³



Alekssei Gorodenkov/Alamy Stock Photo

Soldiers use a military grade laptop.

An emphasis on networks and systems is another attribute of the futurist conception of war, and it is the foundation of network-centric warfare. Also understood as a revolution in military affairs, network-centric warfare is “an information superiority-enabled concept of operations that generates increased combat power by networking sensors, decision-makers, and shooters to achieve shared awareness” and therefore increases lethality.²⁴ Futurists contrast network-centric warfare with platform-centric warfare, which is “a form of fighting where the various military elements, whether they be ships, airplanes, tanks, or soldiers behave as independent actors in the operational environment.”²⁵ Furthermore, the internet and its correspondingly extensive battlefield connectivity enables dispersed operations because of the reduced need for a face to face between commanders.

Futurists argue that there are two main effects of network-centric warfare.²⁶ The first is that it allows for information supremacy over the adversary. This idea reaches its fulfillment during the Gulf War, where American commanders had to explain to surrendering Iraqi commanders where their subordinate units were. The second effect revolves around the “demassification” of the battlefield. By reducing the need for actual interactions, commanders can now order and monitor a subordinate’s every move from another continent with no delay. Both effects undermine several of the principles of war.

“Contemporary doctrinal innovations such as dispersed operations, the effects-based approach, and network-centric warfare all insufficiently understand the nature of war.”

Such arguments place the defenders of the principles of war in a dangerous position. They must defend a list of words against warfighting operations, which argue from the standpoint of effectiveness. Such a disagreement splits apart the necessity of theory for effectiveness. The problem of defending the principles of war rests precisely with their lack of an institutionalized basis in knowledge. There is no framework in which the arguments for, or against, the principles of war can occur. Such a dilemma is fundamentally a failure of doctrine. Doctrine exists as a military organization’s only means to educate and understand what war is. The popularity of new and novel approaches to warfare are theoretical attempts to maintain pace with the rapid technological advances occurring. Such approaches, however, do not educate or enlighten the military officer. Futurist theories of war can only argue from effectiveness, but there is a crucial fault with their argument.

Contemporary doctrinal innovations such as dispersed operations, the effects-based approach, and network-centric warfare all insufficiently understand the nature of war. The value that they do have, if any, is that they provide a descriptive analysis of the changing character of war. There is, however, an important limitation. The lack of conflict against a peer or a near-peer enemy indicates that the character of contemporary war has not yet revealed itself. Contemporary doctrinal innovations characterize a framework of conducting warfare that rests itself firmly upon a vast technological superiority. The one-hundred-page-long orders



US Air Force fighters patrol the no-fly zone over Iraq during the Gulf War.

and the seamless synchronization of kinetic and non-kinetic effects across a battlespace with perfect situational awareness are indicative of a military structure that has become content fighting an enemy which presents no threat to its organizational survival. The futurist claims to operational effectiveness can only validate themselves through combat against an opponent, which can disrupt and overcome our technological advantages; this challenge has not yet occurred.

With no theoretical basis, and a weak basis within the realm of combat effectiveness, the futurist arguments for the revolution in military affairs are questionable. What the principles of war need are a grounding within a theoretical framework. This grounding is an understanding of the nature of war. Instead of emphasizing the changes in contemporary war, as the revolution in military affairs suggests, the required framework focuses on the nature of war, which has been continuous throughout. Jim Storr, in his *The Human Face of War*, stresses that all combat is human combat and that it is purely human factors that characterize the nature of war: “combat is *fundamentally* a human activity.”²⁷ No matter the technology, information connectivity, or intelligence, surveillance, target acquisition, and reconnaissance (ISTAR) assets a military force has available, combat will always be a human affair where “men think, move, and commit violence.”²⁸ The platoon commander’s experience

coming under contact and making real-time tactical decisions, whether it is in Operation IRAQI FREEDOM, or a stability operation in Afghanistan, is the same. Focusing our intellectual efforts on technology without factoring in the dynamic human element misses the mark. Technology is not an end in and of itself. It is a means which educated and competent commanders can utilize to their advantage. Institutions must train their soldiers and officers and not rely upon technology to fight the battle.

“Focusing our intellectual efforts on technology without factoring in the dynamic human element misses the mark.”

The Scientific Foundations of the Principles of War and The Nature of War

Jomini’s writing influenced the institutionalization of the principles of war throughout the nineteenth and early twentieth centuries. However, the principles of war that are now taught in lecture halls receive their direct parentage from J. F. C Fuller’s *The Foundations of the Science of War*.²⁹ Born in the late nineteenth century, Fuller fought in the First World War as a staff officer and was a creative writer on military history on topics ranging from Greek Ancient history to the American Civil War. Fuller is the greatest defender of the principles of war. Fuller built a substantial philosophic system to support his principles. Establishing a threefold order of man, inspired by the Ancient Greek philosopher Plato, and understanding that

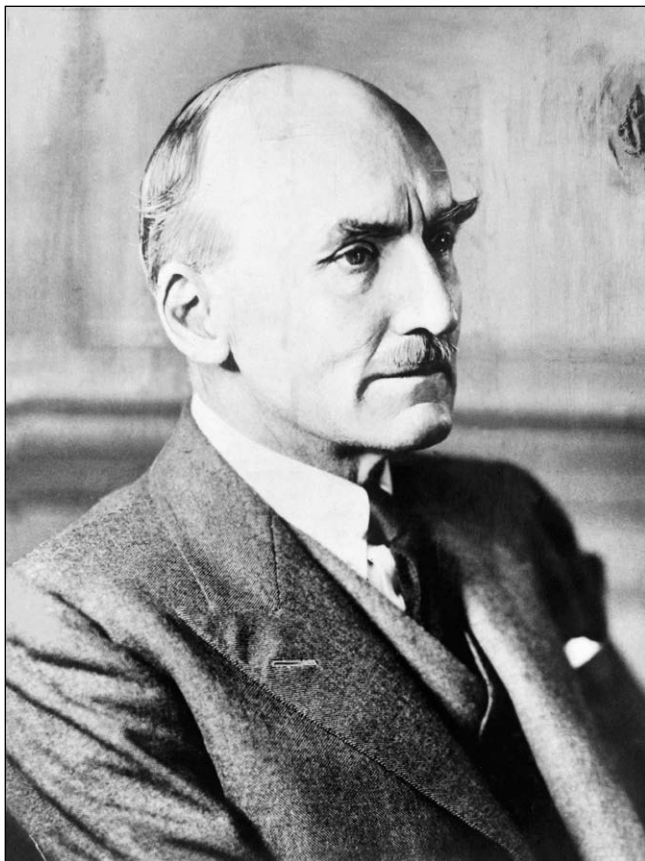

Trinity Mirror/Mirrorpix/Alamy Stock Photo

Major General J.F.C. Fuller.

war is a human affair, Fuller argues that the three conditions of war are mental, moral, and physical.³⁰ From these three conditions of war, each has three elements, corresponding to either command, the offensive, or the defensive, thus creating nine principles of war. Fuller provides the most intellectually robust explanation of the principles of war, and his work is its most vigorous defence.

The essential question is, what purpose does Fuller intend for his principles of war? Tellingly, they appear at the end of his argument. Their foundation is his understanding of the nature of war and man's central role in the conduct of warfare. Here the principles of war are a theoretical system; "it is not possible to correctly apply any one of the principles of war without references to the remainder."³¹ Fuller's principles of war cannot be divorced from the fact that war is a mental, moral, and physical activity. The commander is representative of the mental activities in war. He uses reason and imagination to enforce a will upon his military organization. His soldiers possess offensive power, protective power, and the ability to maneuver this force around the battlefield. The commander must have the courage to enforce his will, and his soldiers must have the morale to obey. Both the commander and his soldiers must overcome fear. The entire structure of a military fighting force rests upon fear. The lack of a courageous will from an army's command will lead to disaster. Fuller wrote that "the shot through the brain," was the ideal method of victory.³² "The brains of an army are its staff... could we suddenly remove these from an extensive sector of the enemy's front the total collapse of the fighting personnel would be but a matter of hours."³³

Furthermore, Fuller, like Jomini, argues that each principle of war is subordinate to a supreme principle of war, but for Fuller, it is the economy of force. "The side which could best economize its force, and which, in consequence, could expend its force more remuneratively, has been the side which has always won."³⁴ Fuller's concept of military force does not merely represent numbers, equipment, moral strength, nor is it generalship but is instead a combination of all three conditions of warfare.³⁵ It is only through his extensive historical examples and logical arguments that Fuller's principles of war derive their value. His theory is a far cry from what now exists within contemporary military doctrine. Currently, the principles of war are an "intellectual framework," which "are vital to efficient war planning and effective command."³⁶ They are orphaned from any intellectual foundations and are philosophically no more than a body experiencing *rigour mortis*. Indeed, when even doctrine admits that "circumstances will dictate the relative weight and importance of each principle," and that it is the commander who must decide what to value given the circumstances, the question must become what value do these principles have if their effectiveness is dependent upon the commander's ability?³⁷

If the principles of war as they are currently institutionalized have no positive effect upon combat effectiveness, then why were

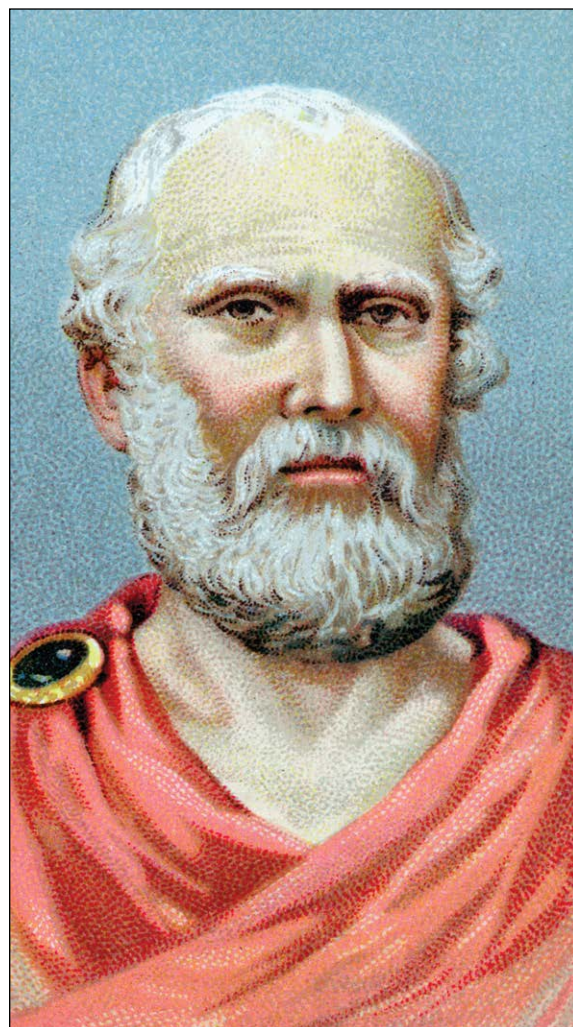

World History Archive/Alamy Stock Photo

Plato.



Sir Hew Strachan.

they so widely accepted? The Swedish scholars Jan Angstrom and J. J. Widen argue that the reasoning why military forces adopted the principles of war is contrary to common perceptions. One such common opinion is that “the principles served as a simple, yet effective, pedagogical tool to teach tactics” to soldiers and junior officers.³⁸ They argue instead that principles of war are “understood as less a reflection of rationalistic concerns of military effectiveness and more as a result of the creation and maintenance of a separate identity of staff officers.”³⁹ If today’s principles of war’s only basis in knowledge comes from other’s experience and if they do not contribute towards military victory, then, reasonably, they can have no value for the military officer preparing for the first battle of the next war. What is necessary is the establishment of a theoretical foundation for the principles of war.

As opposed to the previously described revolution in military affairs, the concept of the continuity war, centred upon its fundamentally human foundation, is also understood as the nature of war. The concept of the nature of war opposes the split conception of war, which sees revolutions or dramatic changes in war from

the past into the present. Sir Hew Strachan, the renowned British military historian and professor at the University of St. Andrews in Scotland, argues that “war shows both continuity and change reflected in the distinction between its character and its nature.”⁴⁰ Every war is different. The weaponry is different; the principal actors, both human and institutional, are different, and lastly, the ground is different. There can be no two identical wars. However, all wars are bound together by the very fact that they are wars. War, as per the law of logical identity, is understood only through the concept of war. “One war is more like another than it is any other human activity, and that is sufficiently true across time for us to identify the nature of war.”⁴¹ Adopting the perspective of the nature of war enables the military officer to understand that human fighting lays at the heart of warfare and it, therefore, depends on moral factors, and that war is reciprocal which means that the “seizure of the initiative and the ability to do the unexpected” is essential to victory.⁴²

Fundamentally the devotees of technology who argue for the revolution in military affairs mistake the character of war for the nature of war. War is, as Clausewitz argues, a chameleon that adapts itself to changing circumstances.⁴³ The characteristics of every war will be different and varying. Understanding this has a significant impact on military education. To focus training upon an aspect of a specific war is to be ill-prepared for the unforeseen. Split conceptions of warfare are indeed not new or novel. In the late nineteenth century, the British found themselves at odds with preparing for a great continental war while also maintaining their overseas empire in so-called colonial wars. Instead of focusing upon one over the other, the answer which the British Army sought was a theoretical confrontation with the diversity of war and an attempt to find coherence amongst it.⁴⁴ The goal of military education, as exemplified by the British 1909 *Field Service Regulations*, is to “train the judgement of all officers so that when left to themselves they may do the right thing.”⁴⁵

“Fundamentally the devotees of technology who argue for the revolution in military affairs mistake the character of war for the nature of war.”

Such arguments do not doubt that the structure of current military organizations is highly efficient. Efficiency is, however, not necessarily combat effective. The efficiency which commanders demand from their headquarters and their staffs is a result of deliberately long planning cycles and an emphasis upon synchronization. Such “close coordination is vulnerable to disruption” and is therefore tactically inflexible.⁴⁶ One must never forget that war is chaos. What is effective is not military organizations that attempt to control this chaos. Effective military units are those who thrive in chaos. “The flexibility to respond to rogue outcomes as they arise is far more important than methodological precautions that attempt to prevent them.”⁴⁷

Conclusion

The principles of war, as now taught, do not contribute to either the theoretical understanding of war or to combat effectiveness. If the commander has not learnt the value of the principles from his own experience or from years of rigorous study, then they are merely words to memorize. It is important to stress that not all historical research is created equal. A study of a historical campaign with the intended purpose of defending a pre-established list of the principles of war proverbially puts the cart in front of the horse. The search for the truths of military history requires that these truths are not already accessible. Wisdom is a result of research, not a prerequisite. The flaw with the principles of war is that no matter the complexity of their defence, they are not understood from reason alone. In other words, there is no mathematical equation that will assist the student in understanding the principles of war. Only lived experience can teach the principles of war. How then can theory, in the expression of contemporary military culture, be a force multiplier? This article mentioned that Napoleon did not list any principles of war. He did not do so because he understood that war is not a static law-abiding subject matter; “circumstances change everything.”⁴⁸ The purpose of military theory is, therefore, not to provide doctrinal

answers to the military officer. Instead, theory is, as Clausewitz wrote, “meant to educate the mind of the future commander, or, more accurately, to guide him in his self-education, not to accompany him to the battlefield.”⁴⁹

The military institutions of NATO should either do away with, or reinvigorate, the principles of war as they currently neither assist in the understanding of what war is, nor increase combat effectiveness. How can this argument coexist with this article’s previous rejection of military ignorance? The answer lies in the distinction between education and schooling. “To cram facts into our men’s heads” is the current means of military schooling.⁵⁰ Military effectiveness demands proper military education. There is a need to integrate a program of serious military history into officer and non-commissioned officer (NCO) training regimes. Such an institutionalization of military history must not force students to search for the confirmation of a pre-set list of principles but have as its only guiding light the dynamic, human element of warfare. The principles of war are only valuable if they contribute to this program.

Fuller wrote that the “central idea of an army is known as its doctrine.”⁵¹ However, he warned that “the danger of doctrine is that it is apt to ossify into a dogma, and to be seized upon by



Andrew Walters/Alamy Stock Photo

NATO logo on the side of an aircraft.

mental emasculates who lack virility of judgement.”⁵² It has been nearly a century since Fuller published his work, and since then, the principles of war have indeed become a hollow and empty laundry list, which reaffirms his characterization of military men as being slaves to tradition.

The principles of war have become a cheat sheet for military officers unwilling to study military history in width and in depth.⁵³ Memorizing the terms *mass* or *concentration of force* will not assist the commander in the decisive moments of combat. A serious study of Napoleon’s decisions at the battle of Austerlitz will, however, develop the commander and help him understand how a thrust into the centre of an enveloping superior army can seize the initiative and lead to victory. As Sir Archibald Percival Wavell, a British general in the Second World War argued:

Study the human side of history... to learn that Napoleon in 1796 with 20,000 beat combined forces of 30,000 by something called economy of force or operating on interior lines is a mere waste of time. If you can understand how a young unknown man inspired a half starved ragged rather Bolshie crowd; how he filled their bellies; how he outmarched, outwitted, outbluffed and defeated men who had studied war all their lives and waged it according to the text-books of their time, you will have learnt something worth knowing.⁵⁴



Pictorial Press Ltd/Alamy Stock Photo

Field Marshal Archibald Wavell who commanded the British Army forces in the Middle East during the Second World War.

NOTES

- 1 Ferdinand Foch, *The Principles of War*, (New York: The H.K. Fly Company, 1918), 12.
- 2 Brian Ettrich, “The Principles of War: Are They Still Applicable?” (master’s thesis, Naval Postgraduate School, 2005), 34.
- 3 Jim Storr, *The Human Face of War*, (London: Birmingham War Studies, 2009), 8. Emphasis added.
- 4 Casey Bronaugh. “Other Principles of War.” (master’s thesis, Naval War College, 2010), 2.
- 5 Carl von Clausewitz, *On War*, trans. Michael Howard and Peter Paret (New York: Everyman’s Library, 1993), 83.
- 6 Maurice de Saxe, *Reveries, or, Memoirs Concerning the Art of War*, (Edinburgh: Sands, Donaldson, Murray and Cochran, 1819), vii.
- 7 J. F. C. Fuller, *The Foundations of the Science of War*. (London: Hutchinson & Co. 1926), 311.
- 8 *Ibid*, 36.
- 9 Canada. Chief of Land Staff, Land Operations, B-GL-300-001 (Ottawa, Canada.: Canadian Army, 2008), 3–5.
- 10 *Ibid*, 3–5.
- 11 U.S. Joint Chiefs of Staff, Joint Operations, Joint Publication 3-0. (Washington, DC: U.S. Joint Chiefs of Staff, 2018), I-1.
- 12 *Ibid*, A-1
- 13 Bruno Colson. *Napoleon on War*. (Oxford: Oxford University Press. 2015), 101.
- 14 *Ibid*, 101.
- 15 Antoine Henri de Jomini, *The Art of War*, (London: Leonaur, 2010), 58.
- 16 *Ibid*, 72.
- 17 Canada. Land Operations, 3–6.
- 18 Jomini, *The Art of War*, 85.
- 19 Clausewitz, *On War*, 83.
- 20 Jomini, *The Art of War*, 46.
- 21 Ettrich. “The Principles of War: Are They Still Applicable?”, 33.
- 22 M. L. Van Creveld, *The Transformation of War*. (New York: The Free Press, 1991), 194.
- 23 Ettrich, “The Principles of War”, 37.
- 24 Christopher Senenko. “Network Centric Warfare and the Principles of War.” (master’s thesis, Joint Forces Staff College, 2007), 1.
- 25 *Ibid*, 5.
- 26 William Callahan. “The Effect of Network-Centric Enabled Distributed Operations Focus on the Principles of War.” (master’s thesis, Army War College, 2008), 5.
- 27 Storr. *The Human Face of War*, 56.
- 28 *Ibid*, 36.
- 29 *Ibid*, 18.
- 30 Fuller, *Science of War*, 178.
- 31 *Ibid*, 252.
- 32 *Ibid*, 292.
- 33 *Ibid*, 292.
- 34 *Ibid*, 204.
- 35 *Ibid*, 204.
- 36 Brian Hanley, “The Principle of War: Uses and Abuses” United States Naval Institute. *Proceedings* 132, no. 10 (October 2005): 46.
- 37 Canada. Land Operations, 3–5.
- 38 Jan Angstrom and J. J. Widen, “Adopting a Recipe for Success: Modern Armed Forces and the Institutionalization of the Principles of War,” *Comparative Strategy* 31 (2012): 264.
- 39 *Ibid*, 283.
- 40 Hew Strachan, *The Direction of War; Contemporary Strategy in Historical Perspective*, (New York: Cambridge University Press, 2013), 266.
- 41 *Ibid*, 203.
- 42 *Ibid*, 203.
- 43 Clausewitz, *On War*, 101.
- 44 Strachan, *The Direction of War*, 202.
- 45 *Ibid*, 202.
- 46 Storr. *The Human Face of War*, 65.
- 47 *Ibid*, 64.
- 48 Colson. *Napoleon on War*, 105.
- 49 Clausewitz, *On War*, 163.
- 50 Fuller, *Science of War*, 309.
- 51 *Ibid*, 254.
- 52 *Ibid*, 254.
- 53 Sir Michael Howard, “The Use and Abuse of Military History,” *The RUSI Journal* 138, no. 1, (1993): 29.
- 54 Col. Thomas E. Griess, “A Perspective on Military History,” in *A Guide to the Study and Use of Military History*, ed. John E. Jessup, Jr. and Robert W. Coakley, 35. Washington, United States Army, 1979.

DND photo by Corporal Ene, 2nd Division Public Affairs.



Captain Isabelle Dubé from 41 Health Services Centre leads her personnel during a farewell parade performed at Ste. Anne's Hospital during Operation LASER in Sainte-Anne-de-Bellevue, Quebec, 17 May 2020.

Emotional Intelligence: Leading through the COVID Crisis

by Daniel Campbell

Nothing tests a leader like a crisis! Anxiety, insecurity, and confusion are the key ingredients to any crises and can quickly become a challenge to all levels of leadership. The Canadian Armed Forces' (CAF) single peacetime focus is to prepare itself for combat, which is the ultimate crises. Through these challenging times we have learned that when basic physiological and security needs are threatened, people feel emotions of fear, anxiety, anger, and confusion. These emotions can paralyze people and a nation from doing what it needs to do most, which is to think and to act.

In 2021, I can't help but reflect on the personal challenges we face as individuals and as a nation. Navigating the chaos of living and working with COVID-19 has required leaders in every rank to demonstrate fighting spirit, which enables us to have the morale, physical, and intellectual ability to endure hardship, operate in dangerous conditions, and to take on our duties with confidence

and tenacity.¹ Leaders have an enormous responsibility; as key enablers and change agents we exercise great influence over our organizations, and each of us, no matter who we are, have the opportunity to shape and alter the environment in which we are operating. I remain inspired by the acts of courage, honour, selflessness, loyalty, and many other positive behaviours that have been demonstrated across our institution.

As the crisis began, military leaders stepped up; adrenaline and coffee drove those first hours, days, and months as the need to absorb, interpret, and disseminate vast amounts of military information to a dispersed workforce challenged every chain of command. Leaders everywhere scrambled to deliver the first message. The first message needed to come from a credible source: accurate, consistent, and timely information is crucial. Get it wrong and many might disregard the message and seek alternate sources to either confirm or disconfirm their personal beliefs.

We learned that during crisis, practices are turbulent, and an individual's interest is often at odds with collective interests. In an age where information is just a click away, we discovered that information anxiety can not only affect the troops but impact leaders as well. For some it was not about having access to enough information and for others it was having too much. Wurman, an expert in information conception, defined information anxiety as:

the state produced by the ever-widening gap between what we understand and what we think we should understand. It is the black hole between data and knowledge, and it happens when information doesn't tell us what we want or need to know.²

But what happens to a leader when self-efficacy is interrupted and replaced by moments of hopelessness and mental fog. I, too, feel the weight of leadership on my shoulders and mind, as the COVID-19 crisis passed the 19th month, feeling emotions of exhaustion, anger, frustration, and hopelessness are natural. The truth is, every person has a breaking point, even the most successful leaders. As leaders, we need to set the example for others and ensure we recognize our own welfare. As General Patton once explained: know when to move and when to rest; "you cannot afford to squander precious resources on creating the mere appearance of non-stop productivity."³

Put your oxygen mask on first, before assisting others.

As an authentic leader, we need to be self-aware, remain true to ourselves and maintain our values even in times of great stress. Remember, as we have all heard before, put your oxygen mask on first, before assisting others. Since leadership is about people and relationships, improving our emotional intelligence (EI) will play a vital role in how we lead authentically and navigate the second wave of this pandemic. If we do not understand our own emotions, we might unintentionally transfer those emotions to others.

The framework for EI was first explained by Peter Salovey and John D. Mayer; quite simply it is the ability to recognize your feelings and those of others.⁴ Daniel Goleman agreed and went on to argue that EI was more important than IQ for achieving success in life, business, and career.⁵

The four domains of emotional intelligence are (a) self-awareness: do I recognize my own emotions? (b) self-management: can I manage my emotions? (c) creating a positive outcome; and (d) social awareness: do I recognize others' emotions and relationship management; can I manage the interaction I have with others constructively and achieve a positive outcome?⁶

To put it succinctly, self-awareness and self-management are about how we manage ourselves, and social awareness and relationship management are how we manage our relationships with others.

Self-Awareness

Self-awareness is the foundation of EI. While our emotions impact our behaviour, performance and relationships with people, being self-aware allows us to be more effective and confident. Simply put, self-awareness drives our moral compass. This is important, given that all leaders have emotional leakage; we need to understand how our emotions impact those around us;. Therefore, a leader's emotions always have public consequences.⁷

If you want to be a successful leader in your organization, the first person you need to be conversant with is yourself!

So how do you know if you are a self-aware leader? Self-aware leaders possess knowledge of themselves and are not scared to share their emotions with others, they are attuned to how they are feeling, recognize their own limitations and are not afraid to poke fun at themselves or use humour. They welcome constructive feedback and are always looking for ways to self-improve. Being self-aware provides the power to change behaviour and improve decision making. Cognitive priming – a concept described in detail by psychologist Daniel Kahnemann – explained that the gap between relating to a situation you have never experienced, and relating to the same situation after just a few minutes of reflection, is enormous.⁸ If you want to be a successful leader in your organization, the first person you need to be conversant with is yourself! An excellent tool to increase your

"I, too, feel the weight of leadership on my shoulders and mind, as the COVID-19 crisis passed the 10th month, and feeling emotions of exhaustion, anger, frustration, and hopelessness are natural."

self-awareness is journaling; keeping a diary of how you are feeling, where you are, what you were doing or thinking about can help you better understand your own emotions. I have found that making space for ongoing reflective practice and combining it with a walk or a run for an added fitness benefit can reduce stress and improve your leadership skills. Reflecting on our emotions when we are not pressed for time allows us to act more efficiently in times of stress. Remember, leaders always provide the energy! "Emotions are contagious, your team will take their cues from you, both the good and the bad."⁹



Nobel Prize winner Daniel Kahneman.

Roger Parkes/Alamy Stock Photo

Self-Management

The best gift you can give your followers is your own state of mind.

The COVID-19 pandemic has certainly challenged leaders to manage their emotions in order to continue to operate during stressful times. Leaders require cognitive resilience or the ability to overcome stressful situations to cope with the current environment. Having the ability to self-manage one’s emotions promotes resiliency and enhances perseverance when confronted by obstacles. The best gift you can give your followers is your own state of mind. Merete Wedell-Wedellsborg labelled it as having a “battle mind” or the mental robustness and belief in your own abilities that enables a soldier to withstand fear, absorb strong emotions, and still react quickly.¹⁰

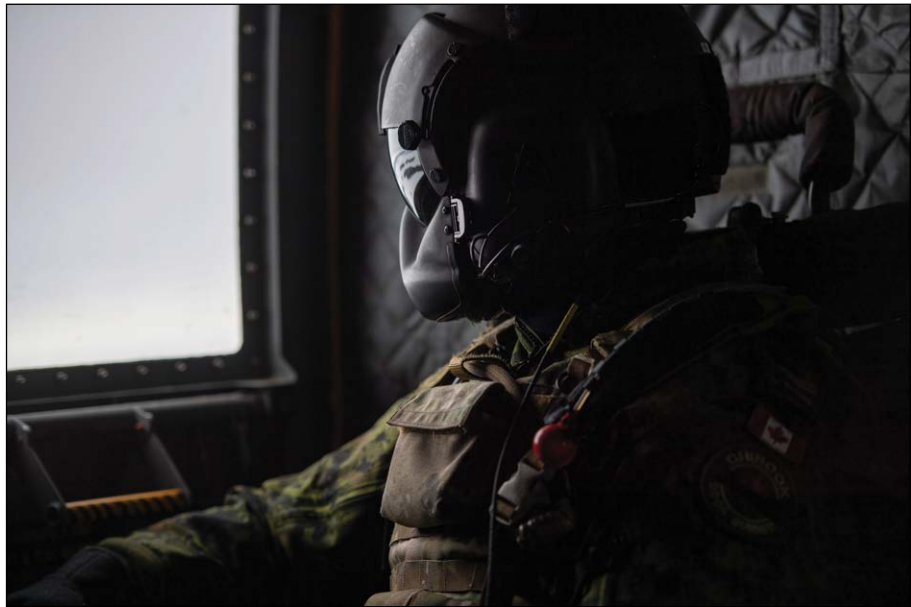

A CH-147 Chinook aircrew member observes while in flight over northern Manitoba during Operation VECTOR, 10 April 2021.

Emotional regulation strategies can be divided into two broad categories: antecedent-focused which occurs before the initiation of an emotional response, and response-focused which occurs after an emotion is already present.¹¹ When a person learns to recognize their emotional responses, they can attempt to avoid the situation that elicits the negative response. It is of course unrealistic to expect leaders to avoid all situations that provoke negative emotions, especially in a military context, whereby soldiers are expected to perform under all conditions. A better

strategy might be to attempt to modify the situation to incite an emotional response that is more manageable.

Quite often we can modify our situation by recognizing what is important and what isn’t. During a crisis it is important to be aware of the things that steal our energy; we cannot afford to drain our battery on applications of no benefit. Not everything can be a priority. Successful leaders prioritize and sustain the focus on the mission. As a response-focused strategy, I frequently analyze a situation and seek out the hidden opportunities; understanding what opportunities exist helps to suppress negative emotions or can assist in masking them with positive thoughts. Gen (Ret) Colin Powell explained that perpetual optimism is a force multiplier, “believing in yourself, believing in your purpose, believing you will prevail, and demonstrating passion and confidence, if you believe and have prepared your followers they will believe.”¹²

Whenever I ask the question, what is the primary responsibility of leaders? The invariable answer is: they look after people! *Duty with Honour* noted that “members of the profession must ensure the care and well-being of subordinates.”¹³ I have found that quite often leaders, in the pursuit of looking after people, seek to protect them from discomfort. One consequence of leaders sheltering people from uncomfortable situations is the loss of a knowledge opportunity, reduced resiliency; and sheltering



General Colin Powell, chairman, Joint Chiefs of Staff, poses for a photograph with soldiers from Joint Task Force B. General Powell was visiting Honduras as part of exercise FUERTES CAMINOS '91.

The Color Archives/Alamy Stock Photo



Winston Churchill with soldiers in 1942.

does little to improve self-efficacy. Remember, leadership, like any muscle must be exercised under challenging circumstances for it to grow.

Self-Efficacy

Self-efficacy can be defined as a person's personal belief in their own abilities and behaviour to address a task or situation and be successful. Bryson noted that a vision of success helps not with predicting the future but with creating it.¹⁴ Likewise, Bandura found that a strong sense of efficacy enhances human accomplishment and personal well-being. He concluded that people with confidence in their capabilities approached challenging tasks as something to be overcome rather than as threats to be avoided. Such an efficacious outlook produces personal accomplishments, reduces stress, and lowers vulnerability to depression.¹⁵ Self-efficacy is built on learned experiences, having completed a task to a successful conclusion, seeing others succeed under similar circumstances, learning from others, and through social re-enforcement, having others believe in your abilities. Contrary to a popular movie tagline; failure is always an option! Winston Churchill once said, "Success is measured by your ability to maintain enthusiasm between failures."¹⁶ As leaders we need to learn to accept failure in the same way we accept success.

Social Awareness

Social Awareness or empathy for others is a critical social competency for leaders. Empathy is not the ability to place yourself in another person's situation; it is the capacity

"leadership, like any muscle must be exercised under challenging circumstances for it to grow."

Social awareness requires us to be present with others; as a young corporal I remember working on an airplane when the commanding officer walked by and stopped to inquire about what I was fixing. He knelt beside me and asked how my family was doing; he knew my wife, my children's names, how old they were, and what sports they liked to play. That interaction always stayed with me; I felt valued, special, and connected. Years later

I met the Commanding Officer, since retired, and recounted the story to him and I asked how he could have possibly known so much about me and my family. His answer surprised me, but never left me: he wrote everyone's name in a book, took notes on their family, and every night he studied another person in his organization. The truth is, followers will forget everything you accomplished, but they will never forget how you made them feel. Leadership can only exist through the strength of the relationship.

Leadership can only exist through the strength of the relationship

It is empirically proven that as emotional beings, social isolation has a detrimental effect on all humans. When we are stressed, we tend to focus on our own needs; worry increases and we can perpetuate a cycle of negative emotions that adversely affect ourselves and others. Another means to release our negative energy is to focus our attention on the needs of others.

I have been thoroughly impressed by those women and men in our ranks who demonstrated such strength of character and sought ways to positively influence people. Purpose and meaning are perhaps the strongest contributors to self-worth and mental well-being and there is no greater purpose for a leader than lifting others.

to actually feel the emotions of others. It is perhaps the most important attribute a leader can possess, because without being attuned to others, it becomes extremely difficult to do what is right or appropriate. Empathetic leaders understand the feelings of others and consider them in their decisions. It is important to note that I am not suggesting decisions should be based solely on emotions or empathy. Decisions need to be balanced; empathy for others is an input in the decision cycle but cannot be the impetus for the decision.

Without social awareness, there are no followers and there are no leaders



DND photo by Corporal Myki Peirier-Joyal

Colonel Asselin, Commander of 4 Health Services Group (4 H Svcs Gp), explains the conduct of operations to members under her command during Operation LASER at Saint-Jean Garrison, 18 April 2020.

Relationship Management

The final EI ability is relationship management; it is where the triad of self-awareness, self-management, and social awareness are put to work. At the heart of relationship management are soft skills, applying our emotional understanding

of ourselves and influencing others through interpersonal communication. To be an effective leader we require the social capacities to communicate vision and inspire confidence in others.

The development of the CAF leadership framework, which outlines the importance of social capacities, defines social capacities as:

a sincere and meaningful behavioural flexibility to be all things to all people, with authenticity, combined with communications skills that clarify understanding, resolve conflicts and bridge differences. These capacities are blended with an interpersonal proficiency of clarity and persuasiveness, team relationships that generate co-ordination, cohesion, trust and commitment, and partnering capabilities for strategic relations building.¹⁷

The old fallacy of military leadership is that there is no place for emotions or connections and that command and control is the best leadership style. Kouzes and Posner in their inquiry about the leadership char-



DND photo by Corporal Geneviève Beaulieu

Commander Mathieu Leroux, JTF(E) Maritime Component Commander, and Chief Petty Officer, 1st Class Michel Giguère, Chief Petty Officer of the Naval Reserve Fleet, deliver a few words of encouragement to their personnel during their shift rotation at the Manoir-de-Verdun long-term care center, in Verdun, Quebec, during operation LASER, 3 May 2020.

acteristics of admired leaders concluded that followers believe the leader must be honest, forward looking, competent, and inspiring.¹⁸ Conversely, one inquiry about generational differences on desired leadership characteristics noted that today's millennial and Generation Z soldiers put more emphasis on caring and self-controlled leadership.¹⁹ The importance of emotional intelligence for successful leadership may never be more relevant than with today's newest soldiers.

The modern battlefield during COVID-19 is situated in the domain of relationship management. The pain of isolation, and the everyday toxicity of social threats must be met with a renewed vigor of honest and caring leadership. Each of us share the responsibility to positively influence our environment. Practicing emotional intelligence skills will aid us in understanding and regulating our emotions and influencing the emotions of others. Self-care is important to all of us, so here are a few things to think about in the coming months:

- Take the crisis, one day at a time.
- Keep things in perspective, let go of things you can't control.
- Take time for reflective practice.
- Believe in yourself!
- Share your feelings; vulnerability always builds trust.
- Set the example with physical fitness.
- Lead with both the heart and the mind.
- Avoid negative people.
- Concentrate on the vision you have for yourself, your family, and finally,
- Recognize the good people in your life and tell them.

"Per Ardua ad Astra" – RCAF motto
(through adversity to the stars)



Corporal Stephanie Patz from 12 (Vancouver) Field Ambulance flies in a CH-149 Cormorant from Vancouver Airport to Victoria Airport, where members will continue on to Quebec, to deploy on Operation LASER, 9 May 2020.

DND photo by Private Daniel Pereira

CWO Daniel Campbell, M.M.M., C.D., M.A. is a Royal Canadian Air Force (RCAF) leader, with a strong interest in leadership and organizational development. He is a graduate of the USAF SNCO Academy in Montgomery, Alabama, and holds a master's degree in Leadership from Royal Roads University. A former aircraft technician, he has served across Canada and on international operations with Fighter operations and Tactical Aviation. He has held senior non-commissioned positions at the Canadian Forces Leadership and Recruit School, The Canadian Forces School of Aerospace Technology and Engineering, and as 14 Wing Greenwood Wing Chief Warrant Officer. He is currently appointed as the 1 CDN Air Division/Canadian NORAD Region Chief Warrant Officer at RCAF headquarters in Winnipeg, Manitoba.



NOTES

- 1 Department of National Defence (DND), "Strong, Secure, Engaged," 2017.
- 2 Richard Saul Wurman, "Information Anxiety," No. 302.234 WUR. CIMMYT. 2001.
- 3 Alan Axelrod, *Patton on Leadership: Strategic Lessons for Corporate Warfare* (New York: Prentice Hall, 2001), 235.
- 4 Peter Salovey and John D. Mayer, "Emotional Intelligence," *Imagination, Cognition and Personality* 9, no. 3 (1990): 185–211.
- 5 Daniel Goleman, *Emotional Intelligence* (Bantam, 2005).
- 6 D. Goleman, R. E. Boyatzis, and A. McKee, *Primal Leadership: Unleashing the Power of Emotional Intelligence* (Boston, MA: Harvard Business Review Press, 2013), 30.
- 7 Goleman, Boyatzis, and McKee, *Primal Leadership*.
- 8 Merete Wedell-Wedellsborg, *Battle Mind: How to Navigate in Chaos and Perform under Pressure* (Saga Egmont International: Kindle edition), 159–160.
- 9 Goleman, Boyatzis, and McKee, *Primal Leadership*, 178.
- 10 Wedell-Wedellsborg, *Battle Mind*, 9.
- 11 James J. Gross, "Emotion Regulation: Affective, Cognitive, and Social Consequences," *Psychophysiology* 39, no. 3 (2002): 281–291.
- 12 Colin Powell, *It Worked for Me (Enhanced Edition): In Life and Leadership* (Harper Collins, 2012).
- 13 Canadian Forces, "Duty with Honour: The Profession of Arms in Canada" (Kingston: Canadian Defence Academy–Canadian Forces Leadership Institute, 2003).
- 14 John M. Bryson, *Strategic Planning for Public and Non-Profit Organizations: A Guide to Strengthening and Sustaining Organizational Achievement* (John Wiley & Sons, 2018).
- 15 A. Bandura, "Self-Efficacy," in *Encyclopedia of Human Behavior*, vol. 4, ed. V. S. Ramachandran, 71–81, (New York: Academic Press, 1994). (Reprinted in H. Friedman [Ed.], *Encyclopedia of Mental Health*, San Diego: Academic Press, 1998).
- 16 Oren Harari, *The Leadership Secrets of Colin Powell* (McGraw Hill Professional, 2002).
- 17 Canadian Forces Leadership Institute, "Leadership in the Canadian Forces: Leading the Institution;" (2007).
- 18 James M. Kouzes and Barry Z. Posner, *The Leadership Challenge*, vol. 3 (John Wiley & Sons, 2006).
- 19 Mecca M. Salahuddin, "Generational Differences Impact On Leadership Style And Organizational Success," *Journal of Diversity Management (JDM)* 5, no. 2 (April 1, 2010), <https://doi.org/10.19030/jdm.v5i2.805>.



DND photo by Corporal Jay Naples

Pilot, Captain Tom Marks flies a CH-146 Griffon helicopter in the Kamloops region during Operation LENTUS, 21 July 2021.

Trained to Fight and Everything in Between

by Bill Cummings

In the *Canadian Military Journal's* summer 2021 edition, Warrant Officer (WO) Ian Daniels has expressed his perspectives related to the Canadian military's role. In *Warrior Spirit*, WO Daniels asserts that Canada's military should be used for naught but winning Canada's just wars. His argument indicates that other conflicts are outside the distinctive skillset of its soldiers: to close with and destroy the enemy. Operations other than war (OOTW) as a mission set, he opines, represent an ideology that conflicts with a soldier's natural instincts. He posits that it is difficult for militaries to adapt their wartime roles to the realities of peace operations, and therefore for these reasons, Canada's military should only be used for the most violent end of the conflict spectrum: war.

On the face of it, this assertion seems reasoned, and one can appreciate the sentiment behind it. If one were a fully qualified professional fire rescue specialist, one could become jaded if constantly called out to retrieve pets from trees with no fire in

sight. It is generally agreed among professions that professionals should only be employed for their profession, and should not undertake work that the "... practitioner is not competent to perform by virtue of the practitioner's training and experience."¹ The Canadian military is considered a collective profession, responsive to the Government of Canada, with all its associated attributes and responsibilities.² So, should this generally accepted professional approach to accepting work not also apply to its soldiers?

The answer to this question is not that simple. The Canadian Armed Forces (CAF) serves Canadians through objectives assigned by the Canadian Government in the national interest. The CAF's role is generally "...to apply force, or the threat of force, in the furtherance of the interests of the state."³ The government has expressed the CAF's role clearly in its 2017 defence policy, *Strong, Secure Engaged*, with eight core missions, four concurrent operations, and nine potential deployments.⁴ The majority of these objectives are OOTW. Moreover, the *National Defence Act* is clear in stipulating that all the "...regular force, all units and other

elements thereof and all officers and non-commissioned members thereof are at all times liable to perform any lawful duty.”⁵ So, though the CAF is a profession, its members are compelled by the *National Defence Act* to fulfill all lawful orders in the pursuit of duty. Their discretion to refuse assigned objectives is limited only to those that are manifestly unlawful. In practice, this translates into the CAF accepting all objectives assigned by the federal government, subject to mitigation through military advice. Hence, the military is employed in a wide range of security activities in the national interest.

Other factors militate against just using CAF members only for war. From the perspective of value for money, it seems highly inefficient to spend our current annual national defence budget of approximately \$21.9 billion⁶ to use the CAF solely for the next existential threat to Canada or one of our NATO collective defence Article 5 allies. The former last happened in 1939, and the latter in 2001. One could argue that Canadian forward defence in Europe during the Cold War served Canadian national interests as much as military deployments in Estonia, Latvia and the Ukraine do so today. None have yet to turn into a hot war.

One of *Warrior Spirit’s* assertions is that OOTW, including peacekeeping, are against a soldier’s instincts to close with and destroy the enemy, the official role of the infantry. One can agree that OOTW are often more cognitively demanding than war. Often, the opposing combatants do not wear uniforms and hide among the population, thereby increasing the risk of collateral civilian casualties and increasing challenges in finding, isolating, fixing, and striking the enemy. To add to this complexity, OOTW employ various and often restrictive rules of engagement that are tailored to the threat environment and type of mission. As an example, United Nations Chapter 6 “peacekeeping” missions employ more restrictive rules of engagement than United Nations Chapter 7 “peacemaking” missions. The challenges increase significantly when belligerents’ use of force transitions surprisingly from Chapter 6-like conditions to Chapter 7-like conditions, with a concomitant need for rapid change in United Forces force posture, mandate, and rules of engagement. The need for agility to rapidly switch between mandate and rules of engagement is one of the reasons why United Nations’ missions in the 1990s were so challenging.

“The need for agility to rapidly switch between mandate and rules of engagement is one of the reasons why United Nations’ missions in the 1990s were so challenging.”



DND photo by Corporal Rachael Allen

Soldiers from the 3rd Battalion, Princess Patricia’s Canadian Light Infantry pass sandbags down the chain to add to the wall during Operation LENTUS in Marsh Lake, Yukon, 11 July 2021.



DND photo by MCpl Chris Ward/ET2010-0015-82

Ordinary Seaman Aaricka Winlaw stands guard to ensure the safety of personnel in the vicinity of the helicopter landing pad, while two Canadian Forces CH-146 Griffin helicopters prepare to land at HMCS *Discovery* during Operation PODIUM.

Operation HARMONY and the 2 Princess Patricia's Canadian Light Infantry Battle Group's (2 PPCLI BG) operations in the Medak pocket area in September 1993 are probably the most emblematic and representative of this challenge. Whilst in the middle of a United Nations Chapter 6 mission, the belligerents rapidly escalated into full combat operations, requiring a rapid transition to Chapter 7-like rules of engagement for 2 PPCLI BG to fulfill its new mission; halt belligerent combat, and return them to pre-combat lines. Lieutenant-Colonel Calvin's BG, despite a lack of United Nations' direction, took initiative and did what was necessary to stop the Croat "ethnic cleansing" of civilian Serbs in the Medak area. 2 PPCLI BG's combat performance was nothing less than exemplary. It was Canadian political election exigencies of the day which prevented this exceptional military operation from being recognized for many years, and which contributed to the mental and moral harm caused to 2 PPCLI BG's soldiers.⁷ The fact that the United Nations' Chapter 6 mission caused so much harm was not attributed to the fact that it was the first major combat action since Canada's involvement in the Korean conflict, but rather, the fact that the government did not recognize 2 PPCLI BG's heroic actions for so long. And it was 2 PPCLI's exhaus-

tive and realistic live-fire war-fighting pre-deployment training, combined with an intent-based command and leadership approach in theatre that was key to their success in the Medak pocket.⁸

Professional soldiers are trained to fulfill their primary occupational role, and such training is rightfully focused on the top end of the spectrum of conflict: warfighting. Prior to deploying operations other than war, or while deployed, soldiers need to be trained on theatre mission-specific tactics, techniques, and procedures, including rules of engagement. A soldier's instincts are therefore not always to close with and destroy the enemy; a soldier's instincts are what the soldier is trained to do for that mission. As a Greek soldier and philosopher once said about performing under pressure, "... [w]e do not rise to the level of our expectations, we fall to the level of our training."⁹ As long as soldiers are trained to perform their duties, they will perform them well, and in the crucible that was Medak, the 2PPCLI BG sunk to the level of its training. As an aside, probably the earliest account of this phenomenon of the Canadian soldier's ability to adapt and sink to the level of their training while on operations is that of the Canadian Corps at Vimy in March and April of 1917.¹⁰

Warrior Spirit's insistence that CAF "...soldiers are trained to be warriors leaves little doubt that they are better suited to fight wars than to engage in peace operations for which they do not have the skills required..." manifestly underestimates the mental acuity and agility of those in uniform. Although they may be trained for warfighting, CAF personnel are highly capable at operating at many levels other than warfighting. In fact, the term warrior is too narrow a term to describe our people's diverse talents.¹¹ Our people are much more capable than just warfighting. It would be more accurate to say that our sailors, soldiers, aviators, and special forces operators are all capable of full-spectrum operations. The majority of a person's career is spent conducting various forms of military service beyond that of operations, let alone combat operations. Most recently, the CAF has supported long-term care facilities in the grip of the Covid-19 pandemic and contributed to vaccine roll-out. We have been there for Canadians in the ice storm of 1998, the Red River floods of 1997 and 2009, the hurricane *Juan* aftermath of 2003, the Toronto snowstorm of 1999, and the Vancouver Olympics and G8 Summit in 2010. Although many of these operations were far from warfighting, they remind Canadians of the excellent calibre of those in uniform, and that we are there to help those we serve *in extremis*.

Although one can appreciate *Warrior Spirit's* desire for a simpler approach to military service, it does not stand up to considered thought. The sheer expense of a military that would

only be employed to deter the threat of war or defend our national sovereignty is an untenable model for Canadians. It would require a standing military of considerable size at high levels of readiness. If the government wished to participate in OOTW, then it would have to develop another security organization to do so, and at considerable expense. *Warrior Spirit's* perspective underestimates

the ability of our service men and women to deliver excellence across a spectrum of conflict and all the rewards such rich and diverse employment brings to our people, and credit to our nation. Lastly, it forgets that CAF personnel can readily adapt to a change in mission in short order. One of the greatest strengths of the CAF is its rapid adaptability as evidenced in Medak, a testament to the versatility of CAF personnel and leadership. If one only identifies as a "warrior," they would be better off releasing from the military to pursue a career as a mercenary, wherein they could choose the wars in which they wished to fight.

"If one only identifies as a "warrior," they would be better off releasing from the military to pursue a career as a mercenary."

Lieutenant-Colonel (Ret'd) W.G. (Bill) Cummings, CD, is a highly-experienced infantry officer from The Royal Canadian Regiment. His 36 years of uniformed service includes operational tours in Cyprus, Bosnia and Afghanistan. Bill is currently employed as a civilian as the Senior Staff Officer Professional Concepts and Development at the Canadian Defence Academy in Kingston, Ontario.



NOTES

- | | | |
|---|--|---|
| <p>1 Professional Engineers Act, R.R.O., Regulation 941, Section 72, Professional Misconduct, para (2) (h), https://www.ontario.ca/laws/regulation/900941/v22#BK88.</p> <p>2 Duty with Honour: The Profession of Arms, (Kingston, ON, Canadian Defence Academy Press, 2009), 10–24.</p> <p>3 Military Justice at the Summary Trial Level, https://www.canada.ca/en/department-national-defence/corporate/reports-publications/military-law/military-justice-summary-trial-level-2-2/chapter-1-the-purpose-of-military-justice.html.</p> | <p>4 Department of National Defence (DND), "Strong, Secure, Engaged," 2017, 17, http://dgpaapp.forces.gc.ca/en/canada-defence-policy/docs/canada-defence-policy-report.pdf.</p> <p>5 Consolidation of the National Defence Act, R.S.C., 1985, c. N-5, https://laws-lois.justice.gc.ca/PDF/N-5.pdf.</p> <p>6 National Defence Budget, https://www.canada.ca/en/department-national-defence/corporate/reports-publications/transition-materials/defence-101/2020/03/defence-101/defence-budget.html.</p> | <p>7 Carol Off, <i>The Ghosts of the Medak Pocket</i>, 2008.</p> <p>8 Multiple interviews with 2 PPCLI BG leadership, April–June 2021; Col (ret'd) Calvin (CO), BGen (ret'd) Brennan (Ops O), LGen Eyre (Recce Pl Comd), LCol Haverstock (Trg O), LCol Beyer (Ops O D Coy), LCol (ret'd) Kaduck (OC B Coy), and LCol (ret'd) Bailey (OC C Coy).</p> <p>9 Archilochus, 650 BC.</p> <p>10 Tim Cook, <i>Vimy: The Battle and The Legend</i> (Penguin Random House Limited, 2018).</p> <p>11 Christian Breede and Karen Davis, "Do You Even Pro Bro?" in <i>Why We Fight: New Approaches to the Human Dimension of Warfare</i>, ed. Robert C. Engen, H. Christian Breede, and Allan English (McGill-Queen's University Press 2020).</p> |
|---|--|---|



PhotoStock-Israelae/Alamy Stock Photo

A Royal Canadian Air Force CP-140 Aurora aircraft in flight.

The Aurora, the Cormorant and the Conundrums of Defence

by Martin Shadwick

It is no less true for being obvious that difficult conundrums and, more to the point, our collective efforts to resolve credibly or reasonably such conundrums, have been fundamental building blocks in the often tortured history of Canadian defence policy and Canadian defence procurement. Two such conundrums today include a successor to the seemingly evergreen CP-140M Aurora maritime patrol/ISR aircraft and on a significant upgrade and fleet expansion (or perhaps even a replacement) for the CH-149 Cormorant search and rescue helicopter. Admittedly, some will posit that there is no short-to-medium term requirement to replace the much-upgraded Aurora given that it continues to perform effectively in a diverse array of military, quasi-military, and non-military applications. Indeed, it successfully prevailed earlier this year against newer aircraft in the USN's Sea Dragon competition in Guam, the first time Canada was invited to this Pacific Rim international anti-submarine warfare (ASW) competition. On the other hand – and herein rests the conundrum – will Canada need to expedite the replacement of the Aurora to preclude potentially credible candidates going out of production (such as the Boeing P-8 Poseidon), failing

to materialize (such as, potentially, the long-projected Franco-German Maritime Airborne Warfare System [MAWS] based on an Airbus product, such as the A320neo), or materializing but with an unacceptable cost, operational capability, or delivery schedule? Nor would one wish the list of would-be Aurora replacement contenders to be limited to types that well-reflect national defence-industrial capabilities and interests (e.g., the Dash 8 P-4) but which are not operationally credible at the required heavier end of the maritime patrol/ISR spectrum.

For the much newer Cormorant search and rescue (SAR) helicopter the situation is rather different. A backbone of search and rescue in Canada, the Cormorant clearly requires an expedited and comprehensive upgrade and fleet expansion, but those initiatives have, most distressingly, been deemed unaffordable based on contractor (i.e., Leonardo) cost estimates. How then is Canada to proceed? More to the point, how is Canada to cope with one of the most challenging search and rescue operating environments in the world and secure the domestic and international credibility of its national SAR system in the absence of a thoroughgoing Cormorant upgrade and fleet expansion? Conundrums, indeed.



DND photo/IHC80-110

The Canadian Forces newest aircraft, the CP-140 Aurora Acceptance Ceremony, CFB Greenwood, 29 May 1980.

The victor in Canada's Long-Range Patrol Aircraft (LRPA) competition of the 1970s, Lockheed's CP-140 Aurora – a hybrid combining the airframe and engines of the P-3C Orion with a mission avionics suite derived from that of the S-3A Viking – was the world's finest ASW-oriented maritime patrol aircraft when it entered Canadian service in 1980. Although fiscal considerations limited Canada's new Aurora fleet to only 18 aircraft and contributed to the demise of a planned civilian remote sensing package – other government departments (OGDs) were amenable to utilizing the package but were loath to make any financial contributions – the life-extended Aurora fleet has now given yeoman service for more than four decades and proved remarkably

adaptable, given a long-running, if at times challenging, series of block upgrades (ably explored by Bernie Thorne in *Canadian Military Journal*, Spring 2021, vol. 21, n^o. 2), to a geo-strategic environment quite different to that prevailing at the time of its acquisition.

Relevant from the outset to a diverse array of military (e.g., ASW), quasi-military (e.g., fisheries and counter-narcotics surveillance), and non-military (e.g., search and rescue) tasks both at home and abroad, the Aurora – particularly in its upgraded CP-140M form – has responded effectively to post-Cold War and post-9/11 peacekeeping, peace-enforcement, human security,

counter terrorism, and other assignments. Some measure of this adaptability, indeed this metamorphosis of the traditional maritime patrol aircraft into a highly flexible multi-mission aircraft, was evident during the NATO-led mission in Libya in 2011. In that operation, Auroras conducted overland intelligence, surveillance, reconnaissance and control, naval gunfire support, overland strike coordination and reconnaissance, maritime interdiction, and psychological operations. Further upgrades to the 14-strong fleet of CP-140M Auroras are currently anticipated.

Although it should prove possible, given sufficient investment, to keep the Aurora serviceable and militarily credible until 2035 or beyond, there is a lurking danger. What would happen if no satisfactory replacement candidate or candidates are available to Canada within the projected timeframe? The proposed Franco-German Maritime Airborne Weapon System – in which there has been a measure of Canadian interest – could still, admittedly, fit comfortably into the projected Canadian timeframe and presumably meet Canadian operational requirements (albeit at a currently undetermined cost) but what if, as now appears likely, MAWS proves abortive? What if the recent German plan to order five Boeing P-8As, although billed as an “interim” solution to replacing their ex-Dutch P-3Cs (and escaping a seriously flawed P-3C life extension and upgrade project), proves something other than interim? What if potentially suitable candidates from other countries (e.g., Japan) are ruled out on interoperability or other grounds? What if smaller and lighter contenders, such as derivatives of regional airliners or executive aircraft, are deemed non-compliant with a future Canadian specification for a truly multi-mission aircraft?

The latter raises an important point. It is quite true that regional airliners, executive aircraft, and smaller turboprops (e.g., the prolific King Air family) have been successfully adapted, utilizing modern sensors and data management systems, to an impressive array of special missions including maritime surface surveillance, intelligence, surveillance, and reconnaissance (ISR) and electronic intelligence-gathering. Indeed, the Canadian content is not unimpressive – modified Dash 7s and Dash 8s have proved popular with the U.S. Army for ISR and related tasks while the USAF is acquiring a squadron’s worth of Bombardier Global 6000s to meet its requirement for a Battlefield Airborne Communications Node (BACN). Domestically, the growing numbers of modified Dash 8s and other types operated by or for OGDs have arguably eroded some of the Aurora’s non-military and quasi-military workload. Nevertheless, and as this column has previously argued, “if Canada aspires, as it should, to an Aurora replacement with the long-range and endurance necessary for challenging mission profiles” (be they in the Atlantic, the Pacific, the Arctic, southern Canada or overseas and be they military, quasi-military, or non-military in nature), “the space and capacity for a full-scope mission avionics suite (including robust ASW, since it is integral to credible general-purpose surveillance/sovereignty protection, security, and marine domain awareness), [the appropriate] armament, adequate quantities of droppable stores (i.e., sonobuoys and SAR kits), and the growth potential to cope with future demands, it is difficult to see how ‘smaller, more affordable’ turboprops and business jets...would suffice.”

If the P-8 goes out of production prior to the projected retirement date of the Aurora – and if similarly-sized aircraft (e.g., MAWS/A320neo) with acceptable capabilities and price points fail to materialize and smaller and lighter candidates are deemed unacceptable – what do we do? We can take a chance and gamble that a suitable candidate or candidates will be on offer closer to the projected Aurora phase-out date but what if that proves to be an optimistic non-starter? It could be posited that the safer play would be the expedited acquisition of an appropriate number (at least twelve?) of the Boeing P-8 Poseidon, modified – where absolutely necessary – to meet Canadian requirements. This concept is not broached lightly given its short-to-medium term cost, the paucity of available defence procurement dollars and the numerous competing demands upon those dollars, the fact that the upgraded Auroras are still operationally credible and the possibility of some residual pushback against a Boeing product given the firm’s conduct regarding Bombardier’s C-Series.

Canada would be in a less tenuous position if the P-8 was guaranteed a production run long into the future but the reality is that most of the P-8s on order for the USN have already been delivered and that the FY22 budget did not include any additional USN orders. A number of factors could admittedly prompt a resurgence of USN orders but there are no guarantees. Export orders continue to arrive at a fairly steady pace but will not keep the production line open for massively extended periods of time.

A different sort of conundrum in nature, scope and ramifications – and in terms of its ability to garner media and other attention and thereby generate political heartburn – surfaced with the belated July 2021 revelation that negotiations for the long-awaited and urgently required Cormorant Mid-Life Update (CMLU) project had been put on pause following the determination, “after a year of consultation,” that the anointed contractor, and original equipment manufacturer, Leonardo S.p.A. (formerly AgustaWestland), “could not do the work at a cost that would respect the project’s overall budget.” In a statement to selected journalists, the Department of National Defence acknowledged “the critical role of the CH-149 Cormorant in supporting our search and rescue operations”, adding that “these aircraft have been in service since 2000 and require upgrades to remain operationally effective and to meet all requirements.” Some “of the onboard systems are already becoming obsolete and increasingly difficult to support including engines. Additionally, the helicopter does not have the required avionics to meet new regulatory standards.”

The Department is “currently working to see what can be done to extend the life of our fleet of...Cormorant helicopters.” One “option is a life-extension of the existing [fourteen] helicopters to meet regulatory requirements and upgrade obsolete parts. This would extend the life of the aircraft and leverage its existing capabilities.” To this end, “intermediate steps are currently being taken within the in-service support program to ensure the helicopter is viable until an upgrade program can be put in place. These measures include: borrowing parts between maintenance and operational aircraft, buying alternative parts, and increasing the maintenance requirements.” We “are examining the impact and options closely, and will communicate further details and updates



A Royal Canadian Air Force CH-149 Cormorant search and rescue helicopter flies for the first time over the city of Lima, Peru, during a flight to test the helicopter's functions during Exercise COOPERACION III, a humanitarian relief exercise, 22 April 2014.

once the reduced project scope is finalized.” The statement added that “replacing the CH-146 Griffon in the search and rescue role [at CFB Trenton] is still a consideration while we are exploring other options for life extending the CH-149 Cormorant fleet.” It also took note of the various enhancements made to CFB Trenton’s SAR Griffons in the past decade.

In an interview with David Pugliese of the *Ottawa Citizen*, Assistant Deputy Minister Troy Crosby noted that the Department of National Defence and the RCAF “will now examine what other options could be available for the [Cormorant] helicopters. “First and foremost, we will ensure the helicopters will remain capable and available. But the [Cormorant] mid-life upgrade project had sought to do more than that and we’ll have to look at what we can achieve through various options.”

Not surprisingly, as Chris Thatcher of *Skies* magazine and others have noted, “DND is now fielding media queries about why cost estimates were not firmer before it announced negotiations with Leonardo in 2018.” In response, DND noted that it had “conducted an extensive options analysis phase with Team Cormorant, led by Leonardo, in which indicative cost estimates for the Norway variant aircraft, the newest configuration of the [AW101], were developed. After more in-depth work in the defini-

tion phase, including refined costing based on a detailed statement of work and performance specification, it was determined that the solution proposed by Leonardo is more expensive than previously thought and outside the project budget.” Actors other than journalists and academics will no doubt also be posing similarly trenchant questions.

In May of 2018, the Trudeau government had announced that it would pursue the Cormorant Mid-Life Upgrade (CMLU) project through “a non-competitive process with the Original Equipment Manufacturer, Leonardo S.p.A. (formerly AgustaWestland)” and its associated defence-industrial “Team Cormorant.” In the view of Leonardo, Ottawa’s decision recognized that “the AW101 [ex-EH-101] is the only helicopter to meet Canada’s primary [rotary-wing] search and rescue requirements and that it has been an excellent [SAR] asset providing outstanding coverage and capability...for RCAF search and rescue squadrons.” The CMLU Letter of Notification released by Public Services and Procurement Canada at that time sought “to inform industry of Canada’s intent to replace or upgrade current and projected obsolete systems on the Cormorant fleet, to augment the current [Cormorant] fleet size” – in part to reintroduce the Cormorant to the Trenton search and rescue region – “and to procure a [Rotary-Wing] Search and Rescue Simulator.” In a subsequent statement,

a DND spokesperson observed that “the “Cormorant Mid-Life Upgrade project will extend rotary-wing SAR services to at least 2040” by upgrading the existing helicopters and augmenting the current fleet of 14 Cormorants with up to seven additional aircraft.

In a press release of 29 May 2018, Leonardo reported that the firm looked forward “to continue working with the Government of Canada to conclude the Options Analysis and finalize the requirements for the CH-149 CMLU and fleet augmentation, simulation and training program. Based on the [Norwegian] AW101-612 standard, Leonardo and Team Cormorant will provide a very low risk solution” – apparently not “low” enough – “to upgrade, enhance and address obsolescence, as well [as] augment the return of the [Cormorant] to all four RCAF [SAR] Main Operating Bases.” The CMLU and fleet augmentation were also expected to reduce the cost of ownership of the fleet.

Speaking at CFB Comox on 22 August 2019, Minister of National Defence Harjit S. Sajjan confirmed that the Cormorant fleet would be upgraded “to extend its life to at least 2042”, that the fleet would be bolstered by “at least two additional helicopters” and that the Project Office would “conduct this work with Leonardo S.p.A. in partnership with IMP Aerospace [and] CAE.” An associated DND Backgrounder confirmed that the Cormorant would be upgraded to the Royal Norwegian Air Force’s impressive AW101-612 standard, adding that the use “of an already established configuration accelerates the project considerably.” Indeed, noted another DND document from 2019, “the overall

project has aggressive timelines to mitigate the impact of the operational risk and obsolescence issues.” It projected the first delivery of an upgraded Cormorant by 2022 with initial operational capability following in 2024. Key elements of the Cormorant Mid-Life Upgrade Project included upgraded flight management, communications, navigation and safety capabilities to comply with new aviation regulations, the introduction of modern SAR mission sensors, upgraded engines, addressing “existing and projected obsolescence while incorporating maintainability and reliability enhancements,” an extended service life, improved in-cabin wireless communications, the return of the Cormorant to CFB Trenton (thereby replacing the supposedly interim and less-than-ideal SAR-configured CH-146 Griffon), and “ensuring there is no disruption to [Cormorant] Rotary-Wing SAR capability during the Project.”

The current machinations with the CMLU project are deeply troubling but they are not surprising. As this column noted in the Winter of 2018 (*Canadian Military Journal*, vol. 19, no. 1), the conundrum “is that eye-watering [SAR] performance often comes with an eye-watering price. Whether the available funds will stretch sufficiently to provide a truly comprehensive and integrated upgrade for the Cormorant, a meaningful increase in fleet size...and other elements of the CMLU package remains to be seen. The need for CMLU is readily apparent – indeed, Canada’s broader SAR credibility is on the line – but there are sceptics who fear that it could amount to a series of piecemeal enhancements and thereby fail to generate vital SAR capabilities or to realize



DND photo by Kevin W. Moore

A Royal Canadian Air Force CH-146 Griffon from CFB Trenton performs a mock rescue training exercise at CFB Mountain View on Prince Edward County Island, South-East of CFB Trenton, 29 September 2009.



A Canadian Forces Search and Rescue CH-146 Griffon helicopter approaches a Jamaican Coast Guard ship to conduct a winching training exercise at the Jamaican Coast Guard facilities in Kingston, Jamaica, 24 August 2011.

the full potential of the Cormorant.” Similar fears and concerns were expressed in at least two subsequent columns.

Barring an apparently substantial amount of additional funding for the CMLU project and/or Leonardo’s wielding of a much sharper pencil, what might a “reduced project scope” entail? At the very least Canada will need to life-extend the 14 remaining Cormorants and address a range of regulatory, obsolescence, serviceability, and availability issues. However, as the ADM noted, the CMLU “had sought to do more than that and we’ll have to look at what we can achieve through various options.” That could prove challenging and instructive. An integrated, comprehensive and full-scope AW101-612-style mission avionics suite would be a non-starter but some useful enhancements, albeit non-integrated, or only partially integrated and less advanced, should be pursued.

The return of the Cormorant to CFB Trenton would effectively be a non-starter. Indeed, if Ottawa’s pledge of “at least two” additional Cormorants actually meant only two (as some media reports infer), there may still not have been sufficient helicopters to provide a truly robust Cormorant fleet – that is, one sufficient to restore *and sustain* a credible Cormorant capability in the Trenton search and rescue region, sufficient to fill potential gaps in coverage as existing Cormorants were removed from active service to undergo upgrades and sufficient to provide for attrition over several

additional decades. Although now, apparently, academic, a pledge of “at least *three*” additional Cormorants would have been much more credible. CFB Trenton’s Griffons will presumably soldier on but there are very real limitations, not necessarily financial limitations, to how many additional SAR enhancements can be accommodated. Those particularly worried about rotary-wing SAR in the Trenton region may well explore making fuller use of existing Ontario-based Chinooks in tandem with the Griffons.

Of course, at least in theory, there are more radical options. Both Sikorsky and Airbus, for example, promoted the acquisition of new SAR helicopters prior to Ottawa’s selection of CMLU and will no doubt take notice of the project’s fate. That said, Canadian governments of all political stripes have found helicopter procurement a tricky business and may not relish the prospect of another full-scale competition. In the final analysis, the demise of the CMLU project as originally conceived may serve only to embolden those who wish, unwisely, to privatize rotary-wing search and rescue.

Professor Martin Shadwick *has taught Canadian Defence Policy at York University for many years. He is a former editor of Canadian Defence Quarterly, and he is the resident Defence Commentator for the Canadian Military Journal.*



BOOK REVIEW

Transforming Command: The Pursuit of Mission Command in the U.S., British and Israeli Armies

Edited by Eitan Shamir

Stanford University Press, 2011

269 pages, \$34.95 (softcover)

ISBN 978-0-804707203-7

Reviewed by Peter. J. Williams

The highly informative British defence blog, Wavell Room,¹ first brought this very good book to my attention. Eitan Shamir is a research Fellow at the Dado Center for Interdisciplinary Studies, Israeli Defence Forces, and teaches in the Security Studies program at Tel Aviv University. In this volume, which the editor purports to be different from other studies on mission command, Mr. Shamir aims to analyse to what extent the three armies in question were able to adopt, adapt and put into practice that concept in the 1980s and 1990s. Shamir uses the Prussian/German historical experience over the 19th and 20th Centuries to set the point of departure for the rest of the work. In defining mission command, Shamir defers, as have many others, to the (“borrowed”, in Shamir’s assessment) German concept of “*Auftragstaktik*,” and defines it as, “Essentially... a contract between the commander and subordinate, wherein the latter is granted the freedom to choose unanticipated courses of action in order to accomplish the mission.”²

Not, so fast, though, Mr. Shamir points out, as in order to fully embrace this concept, armies (and presumably air forces, navies and special forces) must overcome two gaps: the first, between understanding mission command and putting it into doctrine (the “Interpretation Gap”), and the second, (the “Praxis Gap”) between doctrine and its practical application during operations. Each army will negotiate these gaps in their own way, and the main argument of the book is that the strategic setting and organizational culture of each nation will determine how successful they are in making the journey to embedding mission command in their respective organizations. Shamir later compares each army against thirteen different characteristics, and how these affect the culture of mission command

The core of the book is dedicated to an analysis of how each of the armies under consideration fared on this journey. A common feature is that, unsurprisingly, they all experienced successes and failures in pursuing mission command. Somewhat ironically, though *Auftragstaktik* has its birth in the 19th Century, mission command was not formally adopted by the US until the 1980s, by the Israeli’s in 1993, and the British Army in 1995. While this may be a bit of a spoiler alert (and if you think so, skip to the next paragraph now), Mr. Shamir gives the British Army the top grade of the three for most successfully implementing mission command, having had, in his words, “the advantages of “...agility

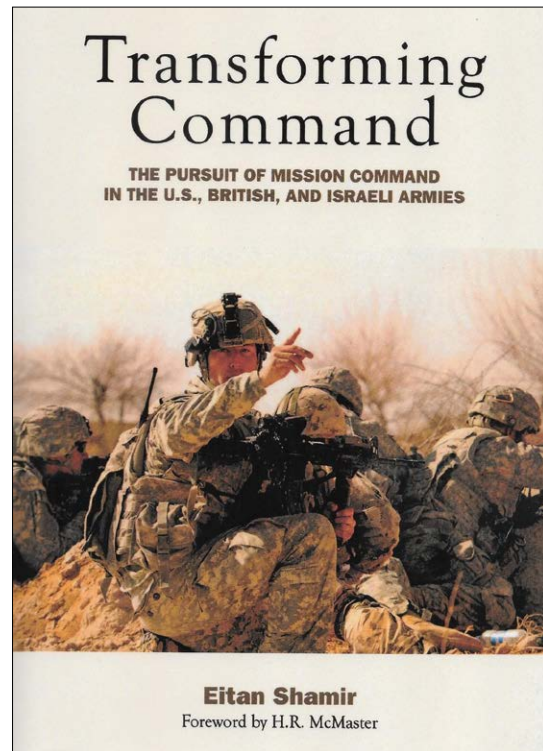

and professionalism.”³ Overall, I found the Editor’s arguments very convincing and would agree with his assertion regarding the importance of professional military education in ensuring that mission command is “baked in” a military’s culture.

There is no bibliography as such, although there are extensive notes running to some 56 pages. Shamir not only made use of extensive secondary source material, but also accounts from commanders and subordinates from the operations discussed. While many readers will be familiar with accounts of the British and American armies’ operations during the period in question, they may be less familiar with the Israeli Army’s operations in the Second Intifadeh (2001-2004), the Second Lebanon War (2006), and Operation *Cast Lead* in Gaza (2008) against Hamas. As such, the book is structured as what the Editor calls, “... an integration of subjective impressions and battle analysis.”⁴ Canada is only mentioned in passing in this book, with an endnote reference to a 1998 article on the implications of the “Revolution in Military Affairs” for the Canadian Forces.

Transforming Command, although published almost a decade ago, remains highly relevant, including for Canada. Our way of war and of commanding continues to draw upon the doctrine of our US and British Allies, shaped by our own experience. Having greatly enjoyed this book, it left me with three questions: First, I wonder how the Canadian Army or the Canadian Armed Forces (CAF) would have fared under similar analysis? Second, though

BOOK REVIEW

this book focuses upon the application of mission command on operations, surely it can also be increasingly practised in garrison settings. Might this not reduce the amount of time required for detailed review of documents (including Power Point slides) at multiple levels before they are presented, pre-briefs before the brief, and so on? Finally, one wonders at the extent to which mission command is embedded within the culture of the armed forces of our potential competitors and adversaries?

The book is particularly recommended for senior leaders who are charged with, *inter alia*, creating a climate of trust within their

commands, and having this culture permeate all levels. It is in such organizations that mission command will flourish.

If there is one major lesson to be taken from this book it is this: it is not enough for armies (or other military forces for that matter) to merely “adopt” mission command. They must also “adapt” it to their particular and evolving circumstances. What a difference an “a” makes...

Colonel Peter J. Williams' *final posting prior to retirement in 2016 was as Director Arms Control Verification on the Strategic Joint Staff.*

NOTES

- | | | | |
|---|--|---|------------------------|
| 1 | See: https://wavelroom.com/ | 3 | <i>Ibid.</i> , p. 197. |
| 2 | Eitan Shamir (Ed), <i>Transforming Command: The Pursuit of Mission Command in the U.S., British and Israeli Armies</i> (Stanford: Stanford University Press, 2011), p. 3 | 4 | <i>Ibid.</i> , p. 131. |